



The Active Aqua difference

Active Aqua's pumps are built to last with premium components, BPA-free, and engineered specifically for hydroponic systems, fresh water aquariums, and ponds.



Customer rated #1 pump for Aquaponics!



- Adjustable Flow Regulator Optimizes Flow & Saves Energy**

Available in six sizes, our pumps offer a range of flow rates from 87 to over 1000 GPH.

- Dual-Function – Use Submersible or Inline**

To switch to inline, simply open the screen housing, remove the mesh filter, and attach the barbed fitting to the inlet side.

- Venturi Intake Aeration Kit**

Models AAPW250–AAPW1000 allow you to naturally oxygenate your water.

AN INSIDE LOOK AT QUALITY

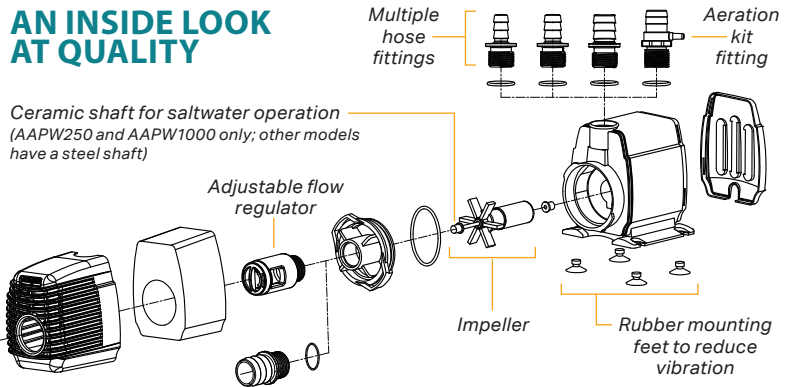

VENTURI INTAKE provides air induction when the airline is connected and pump is running.

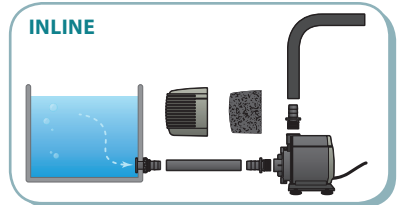
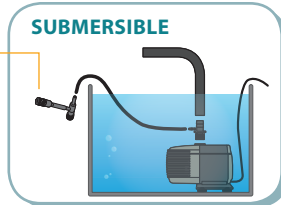

FEATURES

- Indoor / outdoor use
- Oil free / safe for aquaponic use
- UL-listed
- Multiple hose fittings for versatility
- 10 ft. heavy duty power cord
- Rubber mounting feet to reduce vibration and lengthen pump life
- Active Aqua pump bags available to prevent clogging and reduce cleaning maintenance

HEAD HEIGHT CHART – FLOW RATE (GPH)

