



40W

VOLTAGE: 120-277V **WATTS:** 40W

SKU: IL-4025FSG-120 Emergency Green LED

SKU: IL-4025GreenBB Emergency Green LED

PROJECT:

TYPE:

COMMENTS:

PREPARED BY:

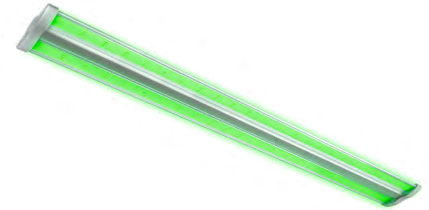

TECHNICAL SPECS

Waterproof Rating	IP65 for Damp/Wet Conditions
PPF	64 $\mu\text{mol/s}$
Efficacy	1.6 $\mu\text{mol/J}$
LED Lifespan (90%)	55,000+ hours
Power Factor	$\geq .95$
Ambient Temperature	0 - 35°C / 32-95°F
Relative Humidity	98%
Frequency	50 / 60Hz
Heat Output	136 BTU/h
Min. Power Factor	0.9
Typical Power Consumption	40W in AC operation,
Typical Power Consumption	15W in Battery Backup operation
Emergency Function Time	1.5 hours

ILW GREEN LED SPECTRUM

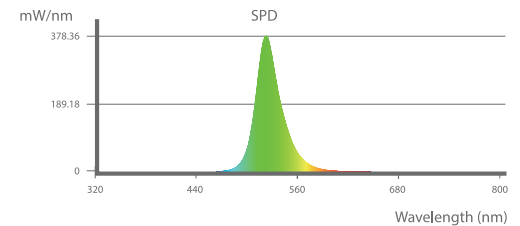

FEATURES

- Easy installation in new construction or retrofit
- Stainless steel mounting brackets are standard

VOLTAGE AND AMPERAGE

120V	0.32A	38W
208V	0.19A	39W
240V	0.18A	40W
277V	0.16A	41W

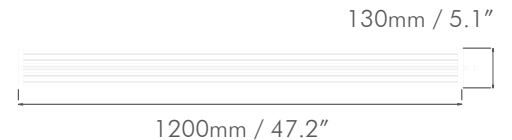

iLW GREEN PHYSICAL SPECS

Height	29mm / 1.14"
Width	130mm / 5"
Length	1200mm / 47.2"
Weight	1.3kg / 2.86 lbs

BATTERY BACKUP PHYSICAL SPECS

Height	72mm / 2.83"
Width	125mm / 4.92"
Length	505mm / 19.88"

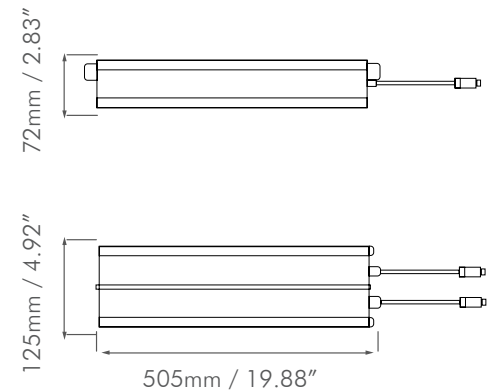

Any component that fails due to manufacturing defect is guaranteed for 5 years. The warranty does not cover physical damage, abuse or instances of uncontrollable natural forces. See the full ILUMINAR Lighting warranty document for detailed information.



iluminarlighting.com
Toll Free: 1-877-540-5588



© Copyright 2022 ILUMINAR Lighting
Subject to change without notice.