



Air Sniper Spectrum-800



FEATURES

Whisper Quiet Operation

Minimal Maintenance

Bluetooth Enabled

99.9% Destruction of Microorganisms
Scientifically proven to destroy 99.9% of airborne viruses, bacteria, and molds.

SPECIFICATIONS

Power Requirements:	110V AC, Single Phase, 50/60Hz
Energy Consumption:	6 Amp Max @110V AC
Weight:	75 lbs (34 Kg)
Fan Speeds:	10 Fan Speeds
Bulb:	300 Watt
Dimensions:	24.5"(w) x19"(D)x 42.5"(H)
Electrical safety certification:	cETLus, UL and CSA Standards
CFM:	300-800 CFM
Noise Level:	21-49 dB (A)
Warranty:	5 Years
Monitoring:	Bluetooth Enabled for remote scheduling and monitoring
Bulb Life:	6+ Years (55,200 Hours)



DETAIL DRAWINGS

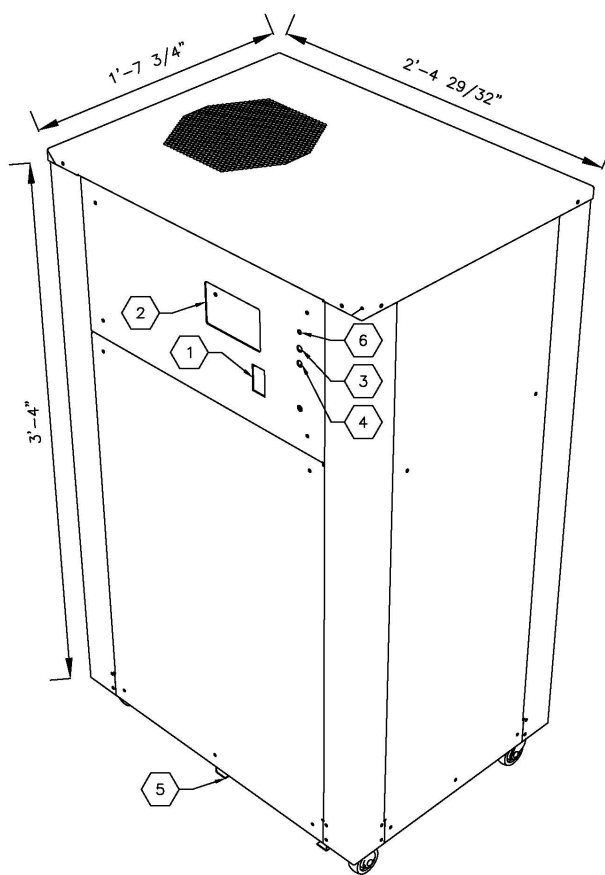
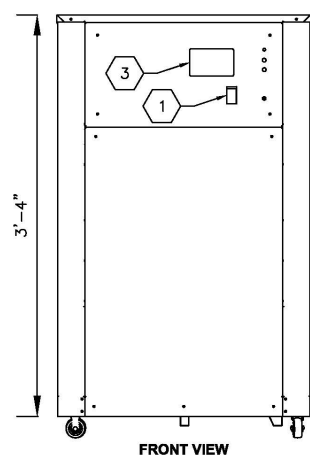
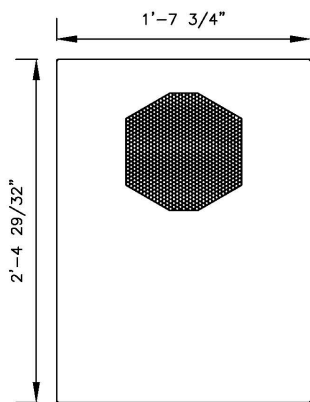

LEGEND	
ITEM	DESCRIPTION
1	POWER SWITCH
2	DISPLAY SCREEN
3	LAMP LIGHT INDICATOR
4	FAN INDICATOR LIGHT
5	FILTER (NOTE 1)
6	FILTER RESET BUTTON

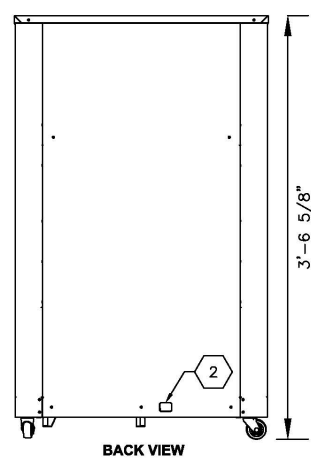

NOTES:

1. THIS FILTER IS A MERV 8 FILTER SIZED 10" BY 18" BY 1", AND SHOULD BE REPLACED EVERY 3 MONTHS.