

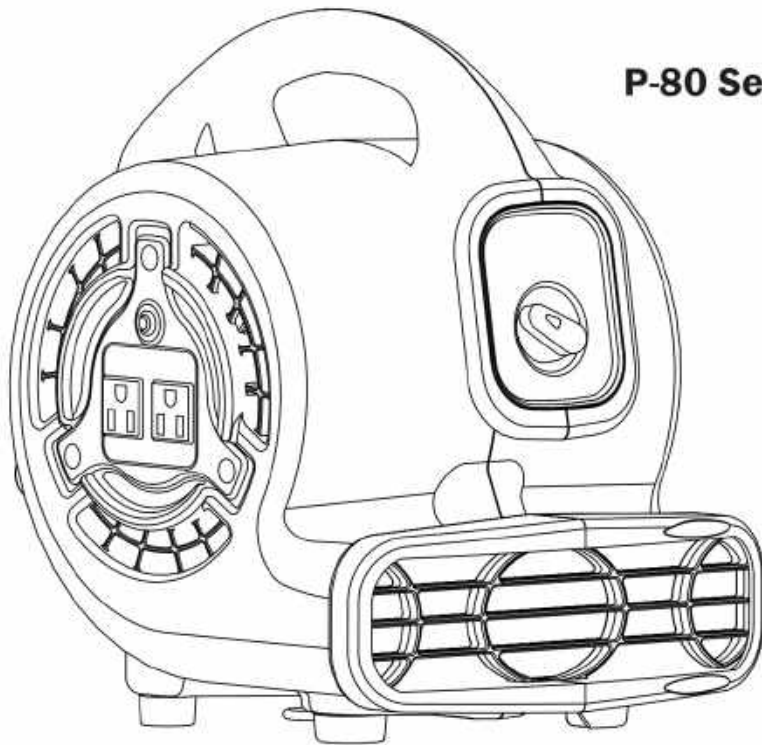

Air Mover Owner's Manual



Model :
P-80 Series, P-100 Series, P-130 Series
P-200 Series, P-230 Series

Read and save these instructions

(115V 60Hz)



Intertek

www.xpower.com | 1-(855)-855-8868 | info@xpower.com

Index: NA-1-A3
Edition: 1.0.Final

Safety Instructions

⚠ WARNING - READ AND SAVE THIS INSTRUCTIONS BEFORE USING THIS PRODUCT.

The user of electrical products may create hazards that include, but are not limited to injury, fire, electrical shock. Failure to follow these instructions may damage and/or impair its operation and void the warranty.

- Before operating, remove all packaging material and check for any damage that may have occurred during shipping or any missing items.
- Check household power supply to ensure it matches the appliance's specification.
- **DO NOT** operate any fan with a damaged cord or plug. Discard fan or return it to an authorized service facility for examination and/or repair.
- Use only on GFCI protected receptacles. Please contact a qualified electrician for verification and / or installation of a GFCI receptacle if necessary.
- **DO NOT** run cord under carpeting. **DO NOT** cover cord with throw rugs, runners, or similar coverings. **DO NOT** route cord under furniture or appliances. Arrange cord away from traffic area and where it will not be tripped over.
- To reduce the risk of fire or electric shock, **DO NOT** use this fan with any solid-state speed control device.
- **DO NOT** touch this appliance or the plug with wet hands or while standing in water.
- **DO NOT** operate the appliance in any pooled water.
- **DO NOT** use the product in areas where gasoline, paint or other flammable goods and objects are used or stored.
- **DO NOT** insert or allow objects to enter any ventilation or exhaust opening as this may damage the appliance and void the warranty.
- **DO NOT** cover the air inlet or outlet on the appliance.
- **DO NOT** direct the air flow at human faces or bodies.
- **DO NOT** allow children to play around or with this appliance.
- **AUTOMATICALLY OPERATED DEVICE** – To reduce the risk of injury, disconnect from power supply before servicing.
- Remove the power cord from the electrical receptacle by grasping and pulling on the power cord plug-end only, **DO NOT** pull the cord directly.
- **DO NOT** attempt to repair or adjust any electrical or mechanical functions of this appliance, as this may cause danger and void the warranty.
- If the appliance is damaged or it malfunctions, **DO NOT** continue to use it. Unplug the product from the electrical outlet. Refer to troubleshooting guide or contact XPOWER.
- Store in a dry area, away from exposure to sunlight, extreme temperature and humidity, or other extreme environments, when not in use.
- **DO NOT** stack more than four units of this appliance.
- An electronic instruction manual can be obtained through manufacture's website www.xpower.com.

Items Included

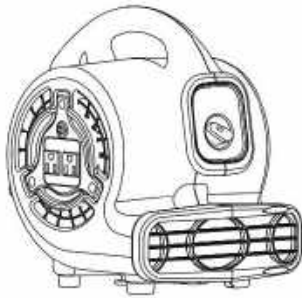

• Air Mover x 1



• Owner's Manual x 1

Parts Description

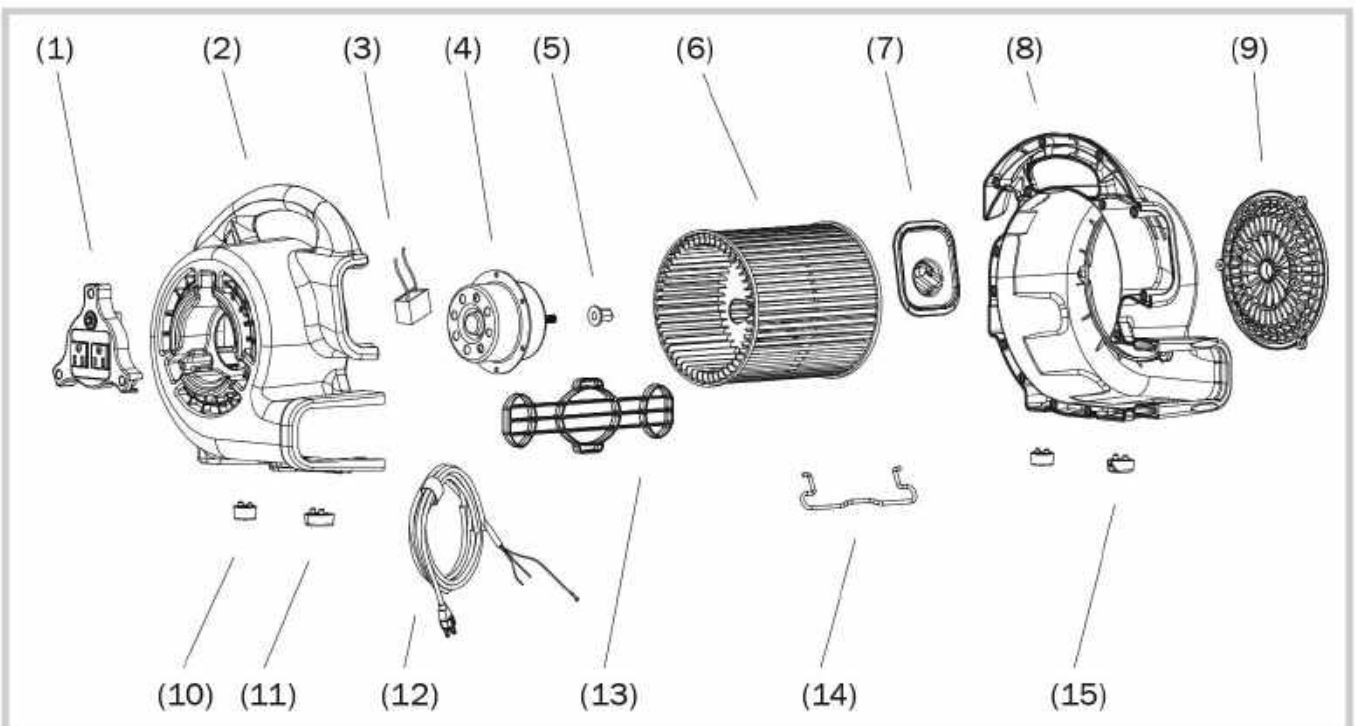

- | | | |
|-------------------------------------|-----------------------------------|--------------------------|
| (1) Inlet Grille Cover (Motor Side) | (6) Fan | (11) Rubber Feet |
| (2) Left Housing | (7) Switch Plate | (12) Power Cord |
| (3) Capacitor | (8) Right Housing | (13) Outlet Grille Cover |
| (4) Motor | (9) Inlet Grille Cover (Fan Side) | (14) Kick Stand |
| (5) Bushing | (10) Rubber Feet | (15) Rubber Feet |

Air Mover Introduction

- The XPOWER Air Mover produces a plentiful airflow capacity for small to large jobs for any location size.
- It is ideal for drying tight spaces such as crawl spaces, under counters, inside cabinets, bathrooms, auto interiors, and more.
- It's also designed for professional carpet cleaning, water damage restoration jobs, or home use.

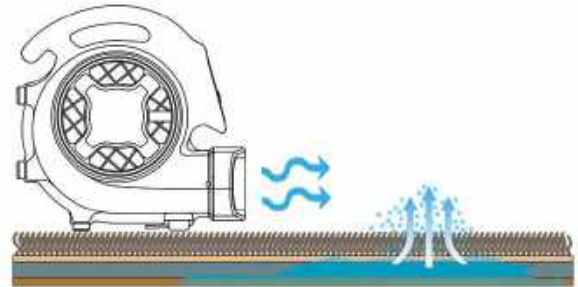

Operation Guide

Drying A Floor

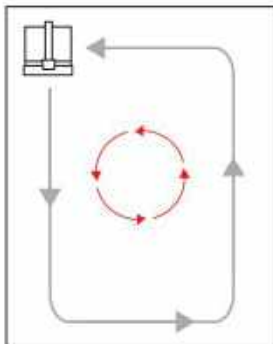

Single Unit:

Place the air mover at the corner to create circular airflow.

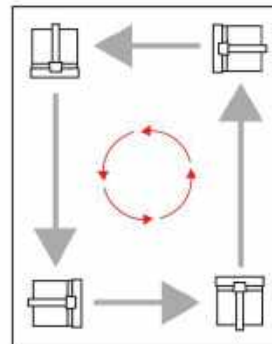

Multiple Units:

Place the air movers at four corners to create circular airflow.

Drying A Wall Or Ceiling

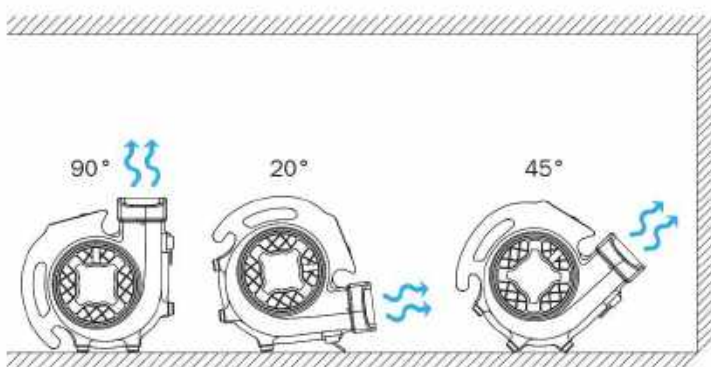

Multiple Operating Positions:

The air can operate at different positions, directing the airflow to desired areas.

Switch Plate

Speed Switch

- Turn to “**OFF**” position to switch the air mover OFF. Turn to any speed position to switch the air mover ON.
- Turn clockwise to set the desired fan speed.
- There are 3 fan speeds from: **1, 2, 3**. “**1**” is the lowest speed and “**3**” is the highest speed.

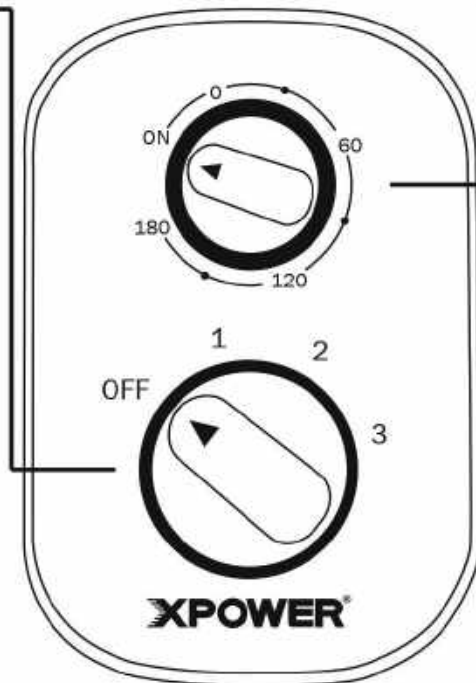

Timer Switch*

- Turn clockwise to set timer for minutes count down to an automatic stop.
- The timer can be set for up to 180 minutes (3 hours).
- When the timer reaches “**0**” position, the unit stops working. On “**ON**” position, it will work constantly.

* The timer switch function does not apply to all models mentioned in this manual.

Additional Electrical Receptacle (Daisy Chain)

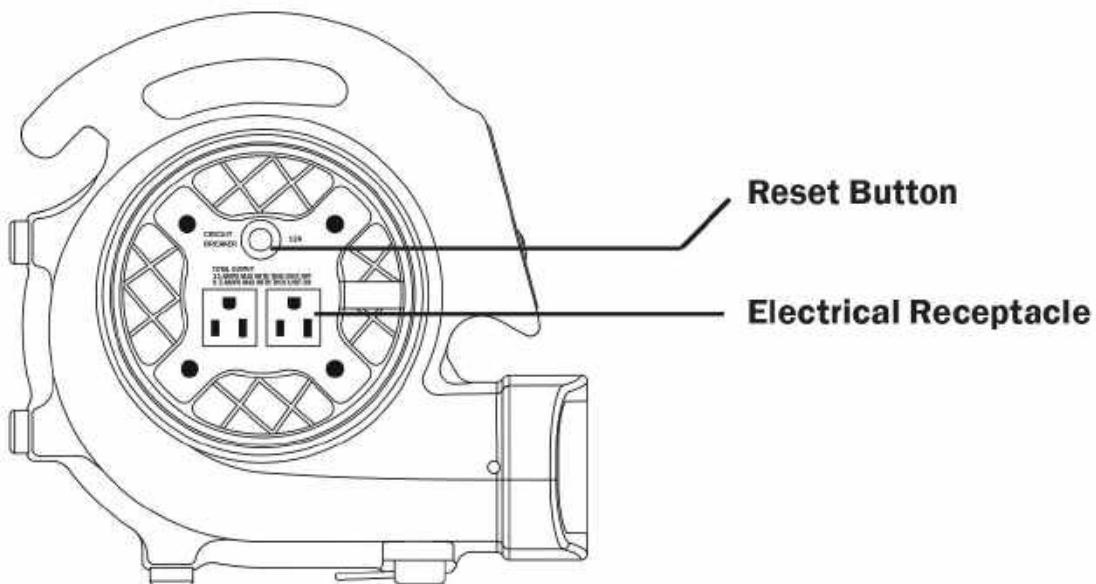

- Other appliances can be plugged in the additional electrical receptacles and work whether the air mover is on or off. However, the total amperage must be lower than the amperage instructed. Different models may have varying instructions.
- If the air mover or the plugged in appliance stops working, press the **RESET BUTTON** to reset the circuit.

Operation Guide (Continued)

Storage

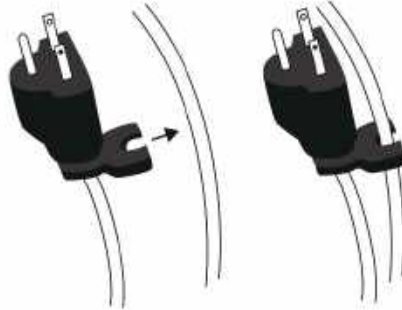
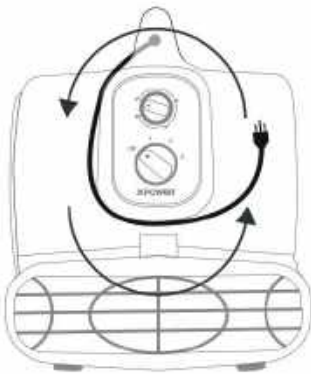

Organize the Cord

- Wrap the power cord around the switch plate for storage after use.
- Use convenient clip at end of cord to secure in place.

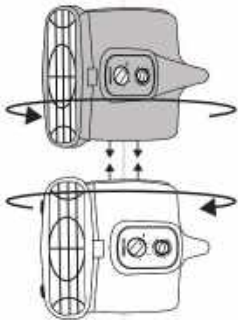

Stack Multiple Units

- Stack the air movers on the sides. Align the air inlets of both air movers.
- Turn the second air mover 30°.

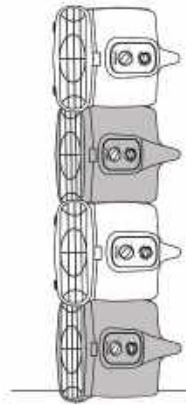

! WARNING

- Do not stack more than four units of this appliance.
- Stacking function is not secure during transportation.

User Maintenance Instructions

Frequent maintenance is recommended on this appliance. Failure to follow the maintenance instructions may cause failure of the appliance and void the warranty.

- When not in use, unplug and store the appliance in a dry and cool indoor place. Make sure it's out of reach of children.
- Before performing any maintenance or cleaning, always disconnect the air mover from its power source.
- Use a damp cloth to wipe the surface of the housing. Do not clean the unit with water directly.
- Check if the grille covers are clean. Remove dirt or any other objects that could block the air inlet and air outlet.
- Do not stack more than four units of this appliance.

Troubleshooting Guide

PROBLEM	POSSIBLE CAUSE	SOLUTION
Air mover does not start	No electricity.	Check for power supply.
	The power cord is not properly plugged in.	Remove and reconnect the power cord.
	The machine is working under an extreme temperature.	Turn off the machine and unplug it. Let the machine cool down to normal temperature.
	The circuit breaker on the additional electrical receptacle (Daisy chain) jumps.	Remove all appliance on the additional electrical receptacle and press "Reset".
	The timer switch is set to "0" position.*	Set the timer switch to "ON" position.*
Unit runs but the speed is abnormal	Air inlet or air outlet is blocked.	Remove blockage.

* The timer switch function does not apply to all models mentioned in this manual.

If troubleshooting does not resolve your problem, please contact XPOWER or other parties authorized by XPOWER for further instructions.

Technical Specification

MODEL NUMBER	P-80A	P-100A	P-130A	P-200AT	P-230AT
Voltage / Frequency	115 V~60 Hz				
Amperage	1.2 A	1.5 A	2.0 A	1.5 A	2.3 A
Motor Power	1/8 HP	1/8 HP	1/5 HP	1/8 HP	1/5 HP
Rated Airflow	475 CFM	500 CFM	700 CFM	600 CFM	800 CFM
Speed Control	3 Speeds	3 Speeds	3 Speeds	3 Speeds	3 Speeds
Timer	N/A			3 hours (OFF)	
Cord Length	10 ft. / 3 m				
Unit Dimension (L) x (W) x (H)	9.3 x 11.5 x 12.3 in. / 23.6 x 29.2 x 31.2 cm	10.7 x 12.4 x 13.3 in. / 27.1 x 31.5 x 33.8 cm			
Unit Weight	7.9 lbs. / 3.6 kg	9.5 lbs. / 4.3 kg	9.3 lbs. / 4.2 kg	8.7 lbs. / 4.0 kg	10.2 lbs. / 4.6 kg
Safety Certification	ETL/C-ETL				

If your product(s) is not listed above, please visit www.xpower.com for more information.

XPOWER Limited Warranty (USA)

1 YEAR LIMITED WARRANTY

XPOWER-branded products purchased in the U.S. from authorized distributors include a 1-year limited warranty. Contact XPOWER to confirm warranty information about your product(s).

This limited warranty covers defects in materials and workmanship in your XPOWER-branded products, purchased in the **U.S. ONLY**. Local warranty policy (if any) in your country will cover products purchased outside the U.S.

IMPORTANT:

- (1) Please finish the online warranty registration before usage. Visit www.xpower.com/service-support/warranty-registration.

XPOWER Limited Warranty (USA) (Continued)

- (2) This Limited Warranty applies with its own timeliness. Contact XPOWER or visit www.xpower.com for more information.

Items mentioned but not limited to below are not covered by warranty:

- (1) Power cord, filters or any other components considered as a “consumable parts” by XPOWER.
- (2) Normal wear and tear.
- (3) Problems that result, directly or indirectly, at XPOWER’s sole discretion, from:
 - (3.1) External causes such as accident, abuse, misuse or problems with electrical power supply.
 - (3.2) Disassembling, servicing or modification not authorized by XPOWER.
 - (3.3) Usage that is not accordance with product instructions stated in Owner’s Manual.
 - (3.4) Failure to follow the product instructions or lack of necessary maintenance stated in Owner’s Manual.

Before contacting XPOWER, please try one or more of the following:

- (1) Consult this Owner’s Manual and follow the instructions of troubleshooting guide.
- (2) Access www.xpower.com for more advice and information that could be helpful to address your problems.

If you need additional assistance from XPOWER, please:

- (1) Email info@xpower.com.
- (2) Call XPOWER U.S. Customer Service Department at **855-855-8868** or other numbers provided on www.xpower.com.
- (3) Visit XPOWER U.S. Head Office at 240 Clary Ave., San Gabriel, CA 91776 or the most current address provided on www.xpower.com.

Please also have your original proof of purchase and the serial number(s) of your product(s) ready when you contact XPOWER.

If you are instructed to return the unit for service or replacement, please:

- (1) Request a RMA (Return-Merchandise-Authorization) number.
- (2) Use the original or an equivalent packaging, prepay shipping charges at your own expense to the address provided by XPOWER, with the RMA number on the shipping label or the packaging.
- (3) Include all the original parts and components.

XPOWER will inspect, assess and advise the repairs needed and applicable cost, if any. For products under warranty, we will pay to ship the repaired or replaced product(s) to you if you use an address within the Contiguous United States. Otherwise, we will ship the product(s) to you at your own expense.



XPOWER Manufacture, INC.

688 S 6th Avenue

City of Industry, CA 91746 USA

www.xpower.com | 1-(855)-855-8868 | info@xpower.com

Read and save these instructions

Index: NA-1-A2
Edition: 1.7.Final