

MOLEAER

ADVANCING NANOBUBBLE TECHNOLOGY

MOLEAER LOTUS NANOBUBBLE GENERATOR

Owner's Manual

IMPORTANT: READ, FOLLOW AND
SAVE THESE INSTRUCTIONS

CUSTOMER SERVICE / TECHNICAL SUPPORT
If you have questions or need to order
replacement parts, please contact:

CUSTOMER SERVICE:

Monday to Friday: 8:00 a.m. to 5:00 p.m. PST

Phone: +1 (424) 558-3567

Email: info@moleaer.com

WEBSITE:

www.moleaer.com

Table of Contents

Safety	2
General Warnings	2
General Information	3
Key System Components.....	3
Quick Startup Guide	4
Suction and Discharge Verification	4
Typical Operating Parameter Ranges.....	5
Specifications	5
Power Input Requirements.....	5
Gas Connection.....	5
Technical Specs	5
Included Accessories	6
Piping Specifications	5
Pump Specifications.....	6
Installation & Startup	6
Pipe Assembly.....	7
Connecting the Oxygen.....	8
System Operation	9
Startup.....	9
Continuous Operation	9
Timed Operation.....	9
Testing for DO	10
Regulator/Flow Control.....	10
Pump Maintenance	11
Drawings	14
Solvent Welding PVC Pipe	15
Cleaning and Sanitizing	17
Operation Checklist	18
Preventive Maintenance Checklist - Recommended Monthly	19
Troubleshooting Guide	20
Limited Warranty	21

Safety



This guide provides operation and maintenance instructions for this product. Consult Moleaer with any questions regarding this equipment.

This Lotus nanobubble generator is for **INDOOR USE WITH OXYGEN ONLY**.

READ AND FOLLOW ALL INSTRUCTIONS.



This is the safety alert symbol. When you see this symbol on your system or in this manual, look for one of the following signal words and be alert for potential injuries.



Warns about hazards that can cause death, serious personal injury, or major property damage if ignored.



Warns about hazards that may or can cause minor personal injury or property damage if ignored.

NOTE

Indicates special instructions not related to hazards. Carefully read and follow all safety instructions in this manual and on equipment. Keep safety labels in good condition; replace labels if missing or damaged.

When installing and using this electrical equipment, basic safety precautions should always be followed.

Risk of Electrical Shock

Connect only to a branch circuit protected by a ground fault circuit interrupter (GFCI). Contact a qualified electrician if you cannot verify that the circuit is protected by a GFCI.

General Warnings

Never open the inside of the pump motor enclosure. There is a capacitor bank that holds electrical charge even when there is no power to the unit.

Code requirements for the electrical connection differ from location to location. Install equipment following all applicable local codes and ordinances.

Before servicing the pump, remove power from the system by unplugging the unit from the outlet.

This equipment is not intended for use by persons (including children) of reduced physical, sensory or mental capabilities, or lack of experience and knowledge, unless they have been given supervision or instruction concerning the use of the appliance by a person responsible for their safety.



RISK OF ELECTRICAL SHOCK. INSTALLERS, OPERATORS, AND OWNERS MUST READ THESE WARNINGS AND ALL THE INSTRUCTIONS IN THE OWNER'S MANUAL BEFORE USING THIS UNIT. THESE WARNINGS AND THE OWNER'S MANUAL MUST BE LEFT WITH THE PRODUCT OWNER.

Suction Entrapment Hazard

Stay off the main drain and away from all suction outlets!

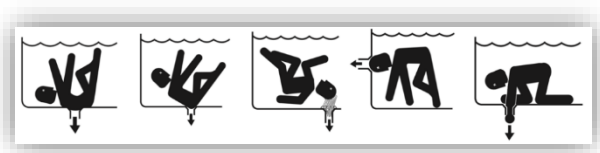

This generator produces high levels of suction and creates a strong vacuum at the main drain (located at the bottom of the body of water). This suction is strong enough to trap adults or children underwater if they come in close proximity to a drain, a loose or broken drain cover, or a grate.



Install all electrical equipment, such as ON / OFF switches, timers, and control systems, etc. to allow the operation (startup, shutdown, or servicing) of any pump or filter so the user does not place any portion of his / her body over or near the pump strainer lid, filter lid, or valve closures. This installation should allow the user enough space to stand clear of the filter and pump during system startup, shutdown or servicing of the system filter.



Hazardous pressure. Stand clear of pump and filter during startup. Circulation systems operate under pressure, when servicing any part of the system, air can enter the system and become pressurized. Pressurized air can cause any part of the pump, filter or valves to violently separate which can result in severe personal injury. Filter lid must be properly secured to prevent separation. Stand clear of all circulation system equipment when starting pump. Before servicing equipment make note of system pressure before opening filter basket.

General Information

Read instructions thoroughly prior to installation and use. **All Lotus products are factory adjusted for optimal nanobubble production.** Note that the actual unit sold may differ slightly from the description in the manual without any difference in the functionality and performance of the unit.

The Moleaer Lotus product is a nanobubble gas-injection technology tailor-made for the horticulture market. Its principal function is to improve the economics of using oxygen for better quality of irrigation water, promote plant growth, and suppress disease. With simplicity and near-perfect efficiency, the Lotus nanobubble generator super saturates irrigation water with dissolved oxygen and trillions of negatively charged nanobubbles. These tiny bubbles, about 100x smaller than a red blood cell, have several unique physical properties that make them behave differently from normal bubbles. Nanobubbles are neutrally buoyant and remain stable in solution for prolonged periods of time, creating an oxygen buffer in the water. The combination of the Lotus's high oxygen transfer efficiency and stable oxygen-enriched nanobubbles enable higher oxygen transfer into the root zone while facilitating nutrient absorption and pathogen suppression.

Key System Components

Figure 1. Lotus Weather-Proof Steel Cabinet

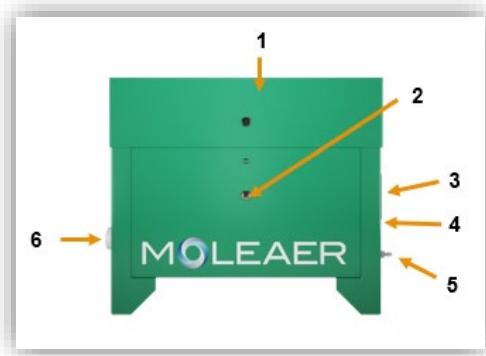

1. Cabinet
2. On/Off indicator light
3. Cooling air discharge
4. Water pump inlet
5. Connection port (Barb fitting included in parts) for external oxygen supply.
6. Water pump outlet

Figure 2. Lotus Pump & Piping

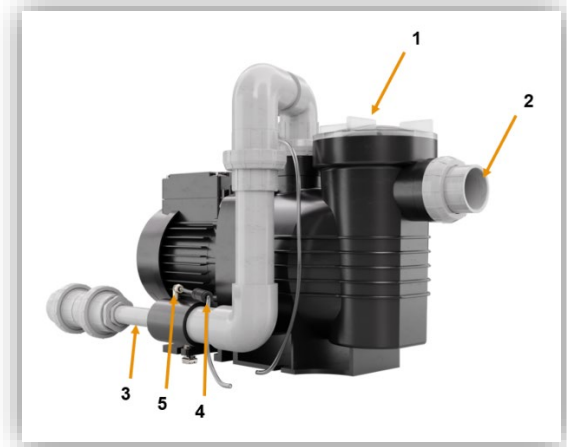

1. 1.5HP self-priming pump with strainer basket
2. Water Inlet
3. Nanobubble generator
4. Gas injection fitting
5. Check valve

Figure 3. Lotus Gauge and Electrical Panel

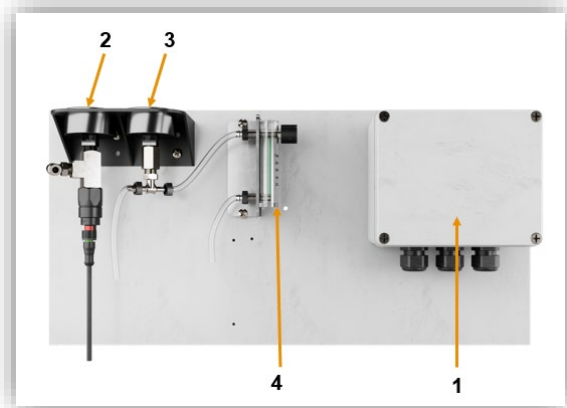

1. Electrical box
2. Water pressure gauge
3. Gas pressure gauge
4. Rotameter

Figure 4. Lotus Solenoid Valve

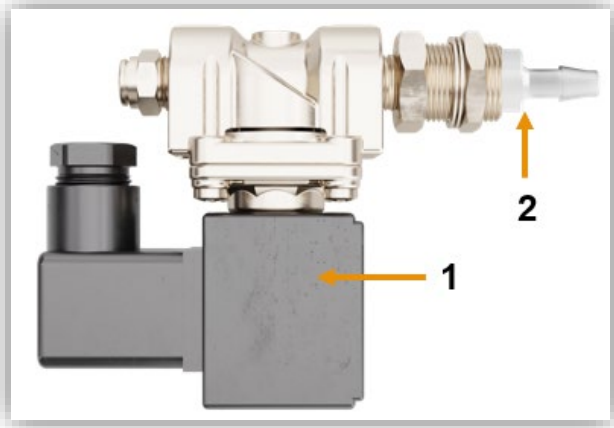

1. Solenoid valve
2. Gas Inlet

Quick Startup Guide

1. Connect the regulator to the O₂ tank, set the dial to 0.
2. Connect the air fitting to the Lotus enclosure.
3. Connect the gas tube between the regulator and the air fitting. Use the snap-grip clamps for securing the tube.
4. Turn the regulator knob to the lowest settings and check for leaks using soapy water spray. Turn the regulator dial back to 0.
5. Open the enclosure of the Lotus by lifting the lid of the box. Open any isolation valves between the unit and tank on both the inlet and discharge pipes.
6. Hand-tighten any loose fittings.
7. Loosen the strainer basket lid from the pump by turning it counterclockwise.
8. With flooded suction, the basket should be filled by gravity. Please see the detailed operating manual for non-flooded suction installations.
9. When the pump strainer fills with water, tighten the pump strainer basket lid by turning the lid clockwise.
10. Turn the Lotus on by pushing the start button.
11. Check that water is flowing through the pump by verifying that the strainer basket is filled with water.
12. Turn the regulator knob to $\frac{1}{4}$ (1/4 lpm). Check for any leaks inside the enclosure at various connection points.

If the pump does not prime after several minutes, turn the Lotus off, review all suction pipe field connections to ensure airtight connections, all valves are open, and try again. Wait five minutes before re-priming to allow the pump seals to cool.

Once primed, large bubbles or a large air pocket should not be visible in the strainer basket. Any visible large bubbles or an air pocket in the strainer basket is an indication of a suction pipe leak. Check suction pipe for leaks and ensure all pipe connections are airtight.

Once the pump is primed and the system is pumping water, visually check for leaks inside the unit and hand tighten any fittings that may be leaking, if hand tightening doesn't stop leaks, shut the unit down, close isolation valves, and disassemble the connections to inspect for any pinched O-rings and that pipes are aligned properly and reassemble.

Suction and Discharge Verification

Observe the suction and discharge locations in the tank. The intake should not create a vortex at the surface. If a vortex is visible, the intake is not properly submerged, adding a 90 inside the tank at the intake parallel to the floor should eliminate this issue. The bubble pattern visible at the surface of the water above the discharge should consist primarily of small bubbles, roughly the size of a pea or smaller. For maximum oxygen transfer, it is important to avoid causing turbulence and splashing as well as disrupting surface tension when discharging. Take care to plan out a discharge path that will cause as little disruption as possible and discharges below the surface of the water.

Figure 5. Lotus Tank Installation by Water Level

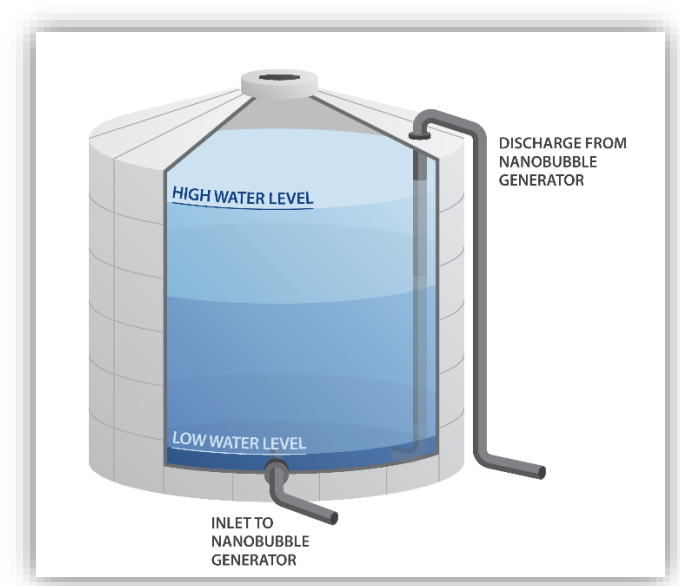

60 Hz (North America)	Single Phase, 115 VAC
50 Hz	Single Phase, 230 VAC

Pipe lengths and unit elevations can play an important role in the performance of the pump. Refer to the Appendix for additional detail regarding the recommended operating envelope for this unit.

Gas Connection

Moleaer Lotus generators come with a 1/4" barb fitting. The unit is designed to be used with industrial-grade oxygen.

Typical Operating Parameter Ranges

The typical operating parameter ranges for the Lotus are shown in Table 1.

Table 1. Lotus Typical Operating Parameter Ranges

Parameter	LOTUS
Gas Pressure (Gauge)	10 –20 psig (0.7 – 1.4 barg)
Liquid Pressure (Gauge)	10 –20 psig (0.7 – 1.4 barg)
Gas Flow Rate (Rotameter)	0.1 – 0.5 cfh (0.05 – 0.24 lpm)

Specifications



Failure to install the Lotus within the limits specified in these specifications may void the system warranty and result in poor nanobubble production and pump cavitation.

Power Input Requirements

Table 2. Lotus Power Input Requirements

Technical Specs

Table 3. Lotus Technical Specifications

Temperature Tolerance, F	40-140
Solids, inches	<3/8
Voltage	120
Phase	1
Running Amps (Standard Household 15 Amp Outlet)	8.2

Piping Specifications

Table 4. Lotus Piping Specifications

Nominal Pipe Size	1.5 in (63 mm)
Maximum Suction Pipe Length	20 feet/4 meters
Maximum Total Pipe Length (Suction + Discharge)	40 feet/8 meters
Recommended maximum Suction Lift	6 feet (2 m) above water surface

Equipped Pump Brand:	Anbull SP-1100A or equivalent
Power	1.5 HP / 1.1 kW
Start Amperage	11.5 A
Voltage	115/230 VAC
Hertz	50/60 Hz
Capacitor	50 µF/250V
Flow Rate	10 – 20 GPM / 2.27 – 4.6 m ³ /h
Head	50 ft / 15.5 m
Temperature (Max)	120°F / 50C°

Pump Specifications

Table 5. Lotus Pump Specifications

Installation & Startup

Customers are responsible for meeting all installation guidelines recommended in this section.









Parts and Accessories

The parts and accessories shown in Table 6 are shipped loose with all Lotus products.

Included Accessories

Table 6. Lotus Accessories

Image	Line Item	QTY	LOTUS
	1	1	Regulator for Oxygen tank with CGA-540 connector
	2	1	Gas Tube
	3	1	Air Fitting

Image	Line Item	QTY	LOTUS
	4	1	CIP Tool
	5	5*	Snap-Grip Clamps
	6	1	Pump Union
	7	2	Pump Union O-Ring
	8	1	Pipe Union
	9	1	Basket Strainer O-Ring
	10	1	Cabinet Keys
	11	1	Quick Start Guide

**Only 2 required. 3 additional included as spares*

The unique site conditions for each site should be carefully considered when identifying the Lotus installation location. Refer to the Location Requirements section of this guide for additional details.

Upon delivery, unbox and inspect the Lotus for any damage or loose parts that may have occurred during transport. Hand-tighten any loose unions.

Location Requirements

Place the unit on level hard ground as close as possible to a power source. Use a concrete pad or pavers to level the placement position.

Parts, Tools, and Materials

The following is a list of various parts, material and tools required for installation and startup of the equipment. As each installation is unique, this is not an exhaustive but a recommended list.

- PVC Glue
- PVC saw
- PVC pipe primer and PVC pipe cement
- PVC Pipe or hose and fittings to connect to the tank.
- Wrench
- Pliers
- Level
- Smoke pen for checking leaks on the suction line
- Spray bottle of soapy water for detecting gas leaks
- Miscellaneous items including tape measure, marking pencil, shop towels for cleaning, etc.

Pipe Assembly

All PVC pipe connections must be solvent welded using PVC cement. Use Schedule 40 polyvinyl chloride (PVC) pipe and fittings. Use PVC cement formulated for wet conditions and fast installation to connect PVC pipe to PVC fittings. Do not use black, acrylonitrile butadiene styrene (ABS) piping or mix ABS pipe or fittings with PVC pipe or fittings. Where necessary, use proper piping support structures to avoid excessive pipe strain.

All PVC pipe connections must be airtight and leakproof. **Failure to provide airtight suction pipe connections may negatively impact nanobubble generator performance.** Large bubbles visible at the pump strainer basket are an indication of suction pipe leaks. Check for and correct all suction and discharge pipe leaks prior to startup.

Proper technique must be used when gluing PVC pipe and fittings to ensure an airtight, leakproof connection. For proper technique, refer to the Appendix. Allow for proper cure time before wet testing suction and discharge pipes.

Installation

The installation diagrams for the Lotus are shown in Figures 11 and 12.

Refer to the pipe connections extending from the base of the Lotus that are shown in Figure 11. Using PVC primer and cement, glue elbows to the first straight, horizontal pipe segments of the suction and discharge piping, and then complete the pipe connections. This may be tied into an existing pipe system, or the installation of a new pipe may be required.

The intake and discharge ports on the Lotus are both 1.5" (63 mm) union fittings. Connect the inlet pipe to the pump (right hand side) and discharge pipe to the union on the left-hand side.

If desired place union valves (not supplied) on either side of the Lotus so it can be isolated for service.

Connect the intake side low on the tank so that the intake is always flooded and connect the discharge return piping higher on the tank, being sure to avoid splashing the water from the return line into the tank.

If the unit is installed in a multi-tank system, ensure that the overflow piping connecting tanks is capable of handling 20 gpm (4.6 m³/h).

Piping

Locate and install the discharge pipe following the recommendations detailed in Figures 11 and 12.

Use available fittings as necessary to route the discharge piping from the Lotus to the Tank

Power Input



Extension cord use is hazardous and should be avoided. In certain jurisdictions, permanent installation using an extension cord is not permitted. Check with your local electrical code.

Step 1. The Lotus requires a dedicated, weather-resistant power receptacle. After starting the Lotus, perform a voltage drop test to verify voltage is within normal limits.

Step 2. When all piping is installed, cure time has been met, and proper circuit operation has been verified, you are ready to startup normal operation of the Lotus.

Connecting the Oxygen

The Moleaer Lotus nanobubble generator is designed for use with compressed oxygen only.



Do NOT mix gases with this system.



All gas fittings and hoses must be maintained free from oil and lubricants.



DO NOT PERMIT SMOKING OR OPEN FLAMES IN ANY AREAS WHERE OXYGEN IS STORED OR HANDLED. THE LOTUS GENERATOR MUST BE SEPARATED FROM FLAMMABLES AND COMBUSTIBLES BY AT LEAST 20' (6 METERS) OR HALF HOUR FIRE WALL.

Gas Flow and Pressure

Inspect the cylinder following the instructions of your gas supplier. Be sure to inspect the regulator to see if the sealing washer is in place on the inlet to the regular.

Connect the gas regulator on the feed gas tank to supply the Lotus. Connect the hose between the supplied regulator and the hose barb on the right side of the Lotus. Install hose clamps. Open valve on Gas tank slowly (counterclockwise), about one full turn. If you hear a hissing sound, there is a leak in the system. Turn the cylinder off and turn the regulator on to relieve any built-up pressure.

Try tightening the regulator to the cylinder and opening the cylinder again. If this does not help, shut the system down again and contact a service representative. NEVER attempt to repair a regulator or cylinder yourself.

Adjust flow on regulator dial by turning the knob clockwise until the desired setting shows through the window. The readings indicated are in liters per hour.

Spray soapy water to gas fittings and connectors to ensure there are no gas leaks. If leaks are detected, then tighten the hose clamps.

Gas flow rates can be adjusted depending on the application and desired effect. The Lotus generators are designed to deliver a spectrum of nano and/or micro bubbles to meet the requirements of the process or application. Low gas flow rates produce more nanobubbles and have a higher gas transfer efficiency, whereas higher gas flow rates produce both nano and microbubbles that have a lower gas transfer efficiency, but higher mass transfer rate. Refer to the specification Table 1 for suggested gas flow rates.

If the cylinder pressure falls below 300 psi (20.5 bar), you should exchange the cylinder for a full one. Turn off the

system, close the cylinder valve, wait for the oxygen to flow out of the regulator, and turn the regulator to the "0" position. NEVER try to remove the regulator unless the cylinder is off, and pressure has been relieved.

System Operation



Pump must be fully primed before initial operation. The pump is capable of self-priming if there is sufficient water in the pump strainer basket.



Operation at or near zero flow can cause extreme heat, personal injury, or property damage.

1. Open the intake and discharge valves to flood piping and prime the pump. **Pump is primed by removing the strainer lid, filling the basket with water, and replacing the lid before starting. It will take a few minutes for the pump to reach full flow and the strainer basket is full, as can be seen through the lid.**

NOTE: If the Lotus generator is located above the water line of the tank or water body, it is important to install a check valve on the end of the intake.



Leaks in suction piping may only be visible while the pump is off, and piping is flooded. Leaks in suction piping may draw air into the system and impact performance.

Press start switch to activate "ON" and run pump at normal operating conditions and check the piping for visible leaks. If necessary, adjust the pipe supports.

NOTE: Normal operating pressure range on the pump is between 13 PSIG and 25 PSIG (0.9 BAR to 1.7 BAR). Pump flow rates should be +/- 10% of the system's designed flow. Pump flow rates lower than the system specifications will result in larger bubbles and lower oxygen transfer efficiencies – it is NOT recommended.



Do NOT exceed 25 PSI (1.72 BAR) on pump pressure.

Every Lotus unit comes with a rotameter (see general arrangement). However, the flow should be controlled by the regulator, with the rotameter knob in the fully open position.

Table 7. Lotus Flow Rates

Model	Maximum Gas Flow (CFH / LPM)	Optimal Gas Flow (CFH / LPM)
Lotus	4 / 2.0	1 / 0.5

Startup

1. Remove the pump basket lid by rotating anticlockwise.
2. Using a bucket, prefill the pump basket with approximately one gallon of water.
3. Reinstall the basket lid, until it is hand tight.
4. Plug the unit power cord into the outlet.
5. Push start switch to start system.
6. Wait until the pump basket fills with water, which can take up to five minutes.

Continuous Operation

Continuous Operation can be selected by toggling the start switch to the "ON" position.

When Continuous Operation is desired, the system will run continuously as long as power is supplied.

The gas injection zone (nanobubble generator) may require periodic cleaning due to built-up inside the piping. If a reduction in gas flow is observed on the rotameter, or the gas pressure gauge increases by greater than 15% from its starting pressure, or if the water pressure decreases by 20% from its initial pressure, cleaning is necessary.

Please refer to Moleaer's Clean-in-Place section of this manual for more information.

Timed Operation

Figure 6. Digital Timer Example



Regulator/Flow Control

Figure 8. Oxygen Regulator



The numbers on the dial correspond to liters per minute. The range is from 0 – 4 liters per minute. The maximum pressure the regulator will allow is 50 PSIG. The gauge on the regulator indicates the gas pressure remaining in the cylinder. The regulator gauge indicating in the red means you should change cylinders. The regulator is designed to attach to industrial gas cylinder the connector is a 540 CGA fitting. Connect the regulator to the cylinder and tighten with a crescent wrench. Do not over tighten; Do not use any oil; Do not use thread tape or paste on the tank or the regulator connections. Connect the supplied hose between the Regulator and the Lotus, clamping the hoses with the supplied hose clamps. Setting the flow rate will be based on environmental factors, such as temperature, volume of water in tank, total water used daily, level of fertilizers and types of fertilizer. Growers have reported values for good plant growth between ¼ and 1/2 liters per minute of Oxygen flow. Do not exceed 2 liters per minute.

If timed operation is desired, purchase a programmable timer capable of handling a 15 Amp circuit and program to start and stop as desired. The one shown above is one of many available online with Wi-Fi functionality and an app for controlling remotely. A typical timed program would be to start the unit a couple of hours before watering and shut it off when a certain desired Dissolved Oxygen level is reached which can be determined after a few days of operating the unit. This time will vary based on environmental factors, such as temperature, the volume of water in tank, total water used daily, level of fertilizers and types of fertilizer. If water is required at different intervals during the day, the timer can be operated in bursts of a minimum of one hour at a time.

Testing for DO

Figure 7. DO Probe Example



If you would like to control for Dissolved Oxygen concentrations, purchase a meter that will test up to 40 ppm. Several are available online. Growers have reported values for good plant growth should be in the range of 14-25 ppm. Be sure to read the instructions that come with the meter when setting it up for the first time and calibrate it according to the manufacturer's instructions regularly. Once the Lotus nanobubble system is operating normally, and the water in the tank is freshly filled, test the DO level continuously while letting the Lotus run, and when the desired DO level is reached make a note of the run time and set up the timer to run for that period (no less than one hour). If the DO level is higher than desired within 1 hour, then the gas flow rate on the regulator should be reduced.

Pump Maintenance

CAUTION

Do NOT open the strainer basket if pump fails to prime or if pump has been operating without water in the strainer basket. Pumps operated in these circumstances may experience a buildup of vapor pressure and may contain scalding hot water. Opening the pump may cause serious personal injury. To avoid the possibility of personal injury, make sure the suction and discharge valves are open and strainer basket temperature is cool to touch, then open with extreme caution.

WARNING

To prevent damage to the pump and for proper operation of the system, clean pump strainer and system regularly.

WARNING

Opening the pump may cause serious personal injury. To avoid the possibility of personal injury, make sure the suction and discharge valves are open and strainer basket temperature is cool to touch, then open with extreme caution. To prevent damage to the pump and for proper operation of the system, clean pump strainer and system every two weeks.

Pump Strainer Basket Care

The strainer basket must be kept clean and free of debris. Inspect basket through the lid on the top of the housing.

Be sure to visually inspect the strainer basket regularly. Dirty strainer baskets reduce filter efficiency and put abnormal stress on the pump motor. Bacterial fouling could cause the lid not to be clear.

Cleaning the Pump Strainer Basket

1. Flip the switch to the OFF position and confirm the red light turns on.



2. Relieve pressure in the system.
3. Close system isolation valves
4. Turn the lid counterclockwise and remove from the pump.
5. Remove debris and rinse out the basket.

6. Put the basket back into the housing. Be sure to align the notch in the bottom of the basket with the rib in the bottom of the housing.
7. Fill the pump basket up to the inlet port with water.
8. Clean the lid and clamp, O-ring, and sealing surface of the pump basket.

NOTE: It is important to keep the lid O-ring clean and well lubricated.

Figure 9. Pump Specifications

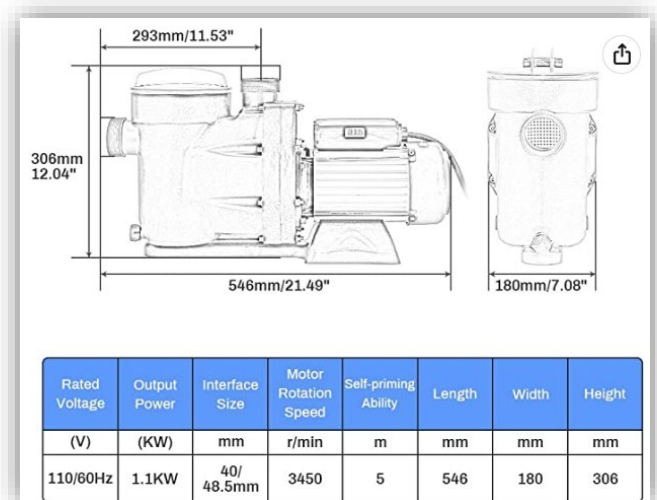

9. Reinstall the lid by placing the lid on the basket. Be sure the lid O-ring is properly placed. Seat the lid on the pump then turn clockwise until tight.
10. Press the switch to the ON position. Confirm green light turns on.



11. Wait until a steady water flow is observable through the pump basket lid.

Winterizing

In mild climate areas, when temporary freezing conditions may occur, run your filtering equipment all night to prevent freezing.

You are responsible for determining when freezing conditions may occur. If freezing conditions are expected, take the following steps to reduce the risk of freeze damage. **Freeze damage is not covered under warranty.**

To prevent freeze damage, follow the procedures below:

1. Shut off electrical power for the pump at the circuit breaker.
2. Drain the water out of the pump housing by removing the one twist drain plug from the housing. Store the plug in the pump basket.

NOTE: Do not wrap motor with plastic or other airtight materials during winter storage. The motor may be covered during a storm, winter storage, etc., but never when operating or expecting operation.

Figure 10. Pump Head Curve

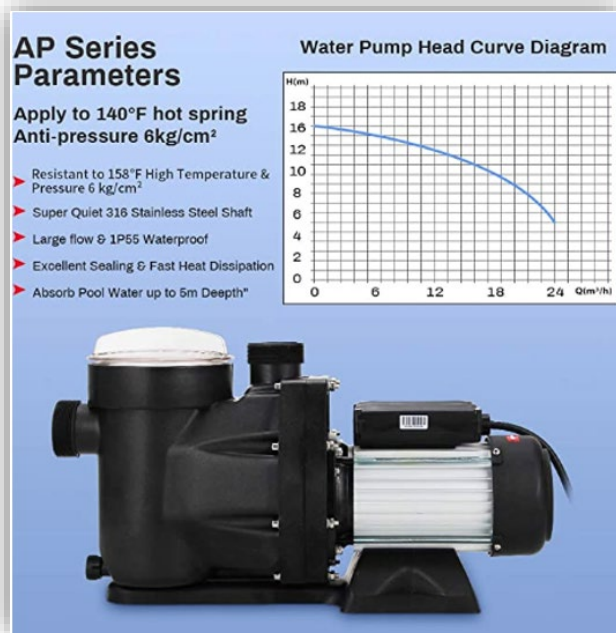

PUMP SERVICE



Always disconnect power to the Lotus generator and / or pump at the circuit breaker before servicing the pump. Failure to do so could result in death or serious injury to service people, users or others due to electric shock. Read all servicing instructions before working on the pump.



Do NOT open the strainer basket if pump fails to prime or if pump has been operating without water in the strainer basket. Pumps operated in these circumstances may experience a build-up of vapor pressure and may contain scalding hot water. Opening the pump may cause serious personal injury. In order to avoid the possibility of personal injury, make sure the suction and discharge valves are open and strainer basket temperature is cool to touch, then open with extreme caution.



Be sure not to scratch or mar the polished shaft seal faces; seal will leak if faces are damaged. The polished and lapped faces of the seal could be damaged if not handled with care.

Motor Care

Protect from Heat

1. Provide ample cross ventilation to prevent overheating.

Protect Against Dirt

1. Protect from any foreign matter or splashing water.
2. Do not store (or spill) chemicals on or near the motor.
3. Protect from any foreign matter or splashing water.
4. Avoid sweeping or stirring up dust near the motor while it is operating.
5. If a motor has been damaged by dirt it voids the motor warranty.
6. Clean the lid and clamp, O-ring, and sealing surface of the pump basket.

Protect Against Moisture

1. If a motor has become wet, let it dry before operating. Do not allow the pump to operate if it has been flooded.
2. If a motor has been damaged by water the motor warranty is voided.

Restart Instructions

If pump is installed below the water level, close return, and suction lines prior to opening the strainer basket on the pump. Be sure to re-open valves prior to operating.

Priming the Pump

The pump strainer basket must be filled with water before the pump is initially started. Follow the steps below to prime the pump:

1. Loosen the pump lid.
2. Allow pump strainer basket to fill with water.
3. Tighten the strainer basket lid. The pump is now ready to prime.



The pump should not run longer than eight minutes if priming is not achieved.



Do NOT run the pump dry. If the pump is run dry, the mechanical seal will be damaged, and the pump will start leaking. If this occurs, the damaged seal must be replaced. ALWAYS maintain proper water level. If the water level falls below the suction port, the pump will draw air through the suction port, losing the prime and causing the pump to run dry, resulting in a damaged seal. Continued operation in this manner could cause a loss of pressure, resulting in damage to the pump case, impeller and seal and may cause property damage and personal injury.

Drawings

Figure 11: Lotus Isometric Installation Diagram

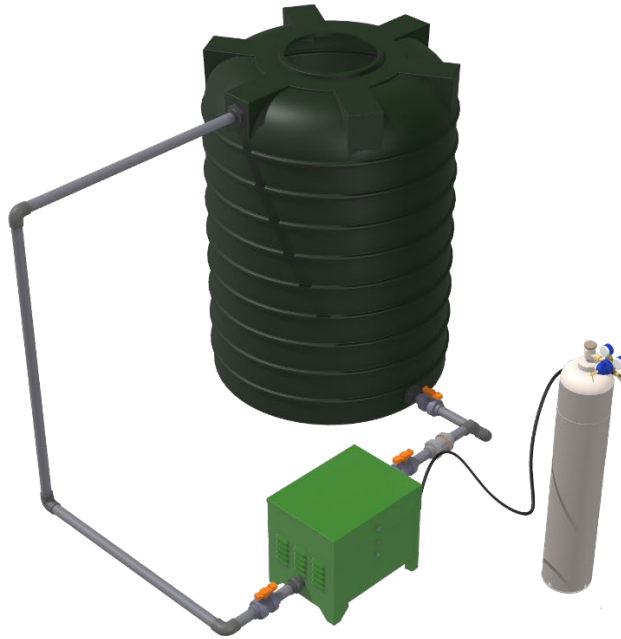

Figure 12: Lotus Installation Diagram from Top

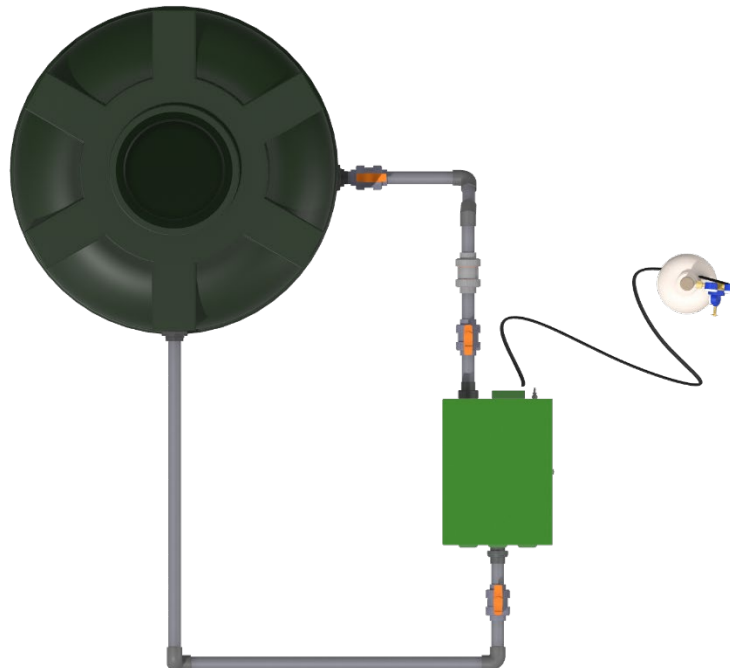
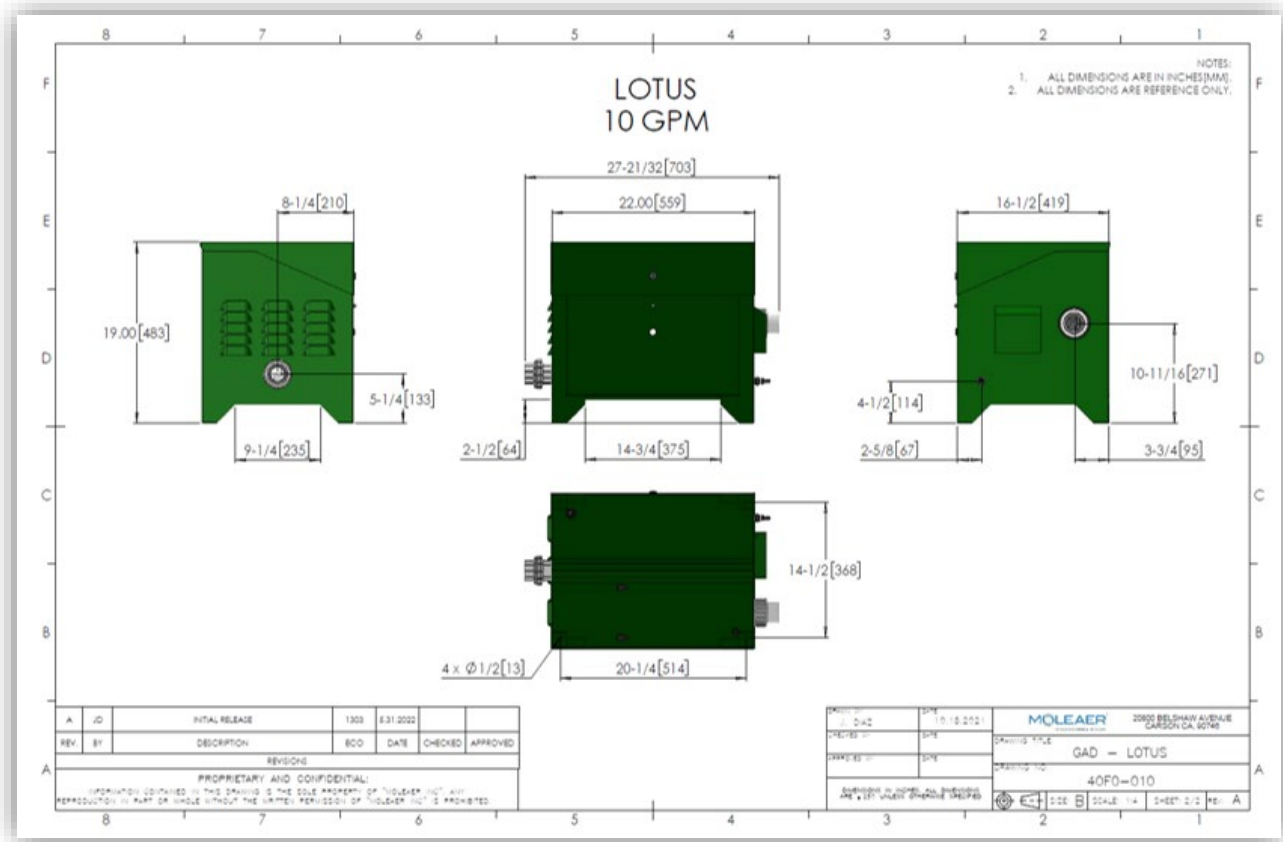

Figure 13: Lotus Enclosure Dimensions



Solvent Welding PVC Pipe

- Once the primer has been applied to both surfaces, the cement must be applied within 5 minutes. If not, you **MUST** prime the surfaces again before applying cement.
- Do Not use primer on ABS pipe and fittings.
- Remember that a thin coating of cement is recommended inside the fitting hub to prevent puddling. Puddling can cause weakening and lead to joint failure.
- Assembly parts **QUICKLY**. Cement must be fluid. Dried cement **CANNOT** be re-coated.
- Lower temperatures and larger diameter pipes may need a little extra hold time
- Allow 15 minutes for good handling strength and 2 hours cure time. Longer cure times may be required at low temperature. **DO NOT TEST WITH COMPRESSED AIR OR GAS.**

How To Solvent Weld

Prior to Use:

1. Read all product labels carefully.
2. Stir or shake cement before using. If gelled, do not use. Keep container closed when not in use. Avoid eye and skin contact. Wear safety glasses with side shields and wear rubber gloves.
3. Cut pipe ends square, Deburr the inside and chamfer the outside of pipe ends, remove all dirt from pipe ends and fitting hubs.
4. Pipe should easily go 1/3 to 2/3 the way into the fitting hub.
5. Clean pipe and fitting hub with a listed cleaner.
6. First apply primer inside the fitting hub, then the exterior of pipe end.
7. First apply liberal coat of cement to exterior of the pipe end beyond fitting hub depth, then inside the fitting hub.

8. Turn pipe ¼ of turn as you push the pipe end into the fitting hub.
9. Make sure pipe end bottoms out inside the fitting hub and hold for 30 seconds to prevent push-out.
10. Wipe off excess cement

Figure 14. How to Glue Piping

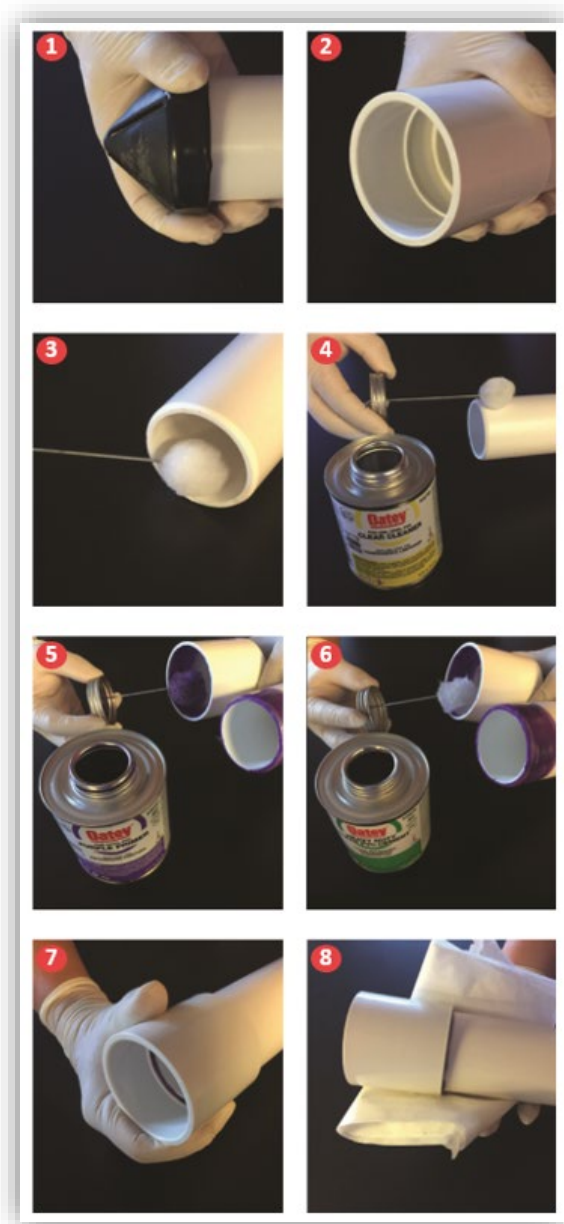

Set Up & Curing Times

The set up/cure time is dependent on several factors. The pipe size, socket fit, ambient temperature, relative humidity, solvent cement used and the system operating pressure should all be considered when determining set up/cure times.

DO NOT test PVC piping systems with compressed air or gas.

NOTES: Cure schedule is the time required before pressure testing the system - This chart can be used as a guideline to determine joint cure

Cleaning and Sanitizing

Nanobubble Generators (NBGs) can become contaminated after they have been used for some time. Pollutants such as colloids, biofilms, mineral scale, and biological matter build up over time. Contaminants can result in decreased performance. Periodic cleaning is thus very important and essential to optimal system performance.

Cleaning of an NBG system when one or all of the following operating conditions occur:

- The system is unable to reach 80% of specified nominal gas flow with gas flow valve wide open.
- The normal increase in dissolved oxygen in one pass has decreased by 25%.
- The pressure of the gas injection required to maintain gas flow exceeds supply gas pressure.

If cleaning is delayed too long, complete recovery of the unit may not be possible.

Safety Precautions

Maximum Temperature: 100°C (212°F.)

pH Tolerance Range: 2 to 14.

Each cleaning situation is different; therefore, specific cleaning recommendations are dependent on the type of foulant. Consult the general cleaning instructions for information that is common to all types of cleaning, such as suggested equipment, pH and temperature limits and recommended flow rates; then apply the specific recommendation as needed.

1. When using any chemical, follow accepted safety practices. Consult the chemical manufacturer for detailed information about safety, handling and disposal.
2. When preparing cleaning solutions, ensure that all chemicals are dissolved and well mixed before circulating the solutions through the system.
3. It is recommended that the system be flushed with good-quality water (20°C minimum temperature) after cleaning. City water quality is recommended. Flush the bulk of the cleaning solution from the system before resuming normal operation. Cleaning chemicals may be present on the treated water side following cleaning, to avoid contamination, the treated water can be diverted to a drain for a few minutes or until the water is clean when starting up after cleaning.

4. Ensure the system power is disconnected during cleaning procedures to avoid accidental startup of the pump or gas production system.

NOTE: The maximum temperature limit during cleaning is 45°C (113°F) for all PVC systems.

NOTE: The minimum and maximum pH limits for all PVC systems are 1 and 13, respectively.

General Cleaning Procedures

The cleaning procedure of an NBG system consists of the following process steps:

1. Turn off the pump and drain any water in the system. Isolate the Lotus from the tank.
2. **Prepare the cleaning solution.** The fluids used for the cleaning process need to be of a certain pH, and all chemicals must be dissolved and mixed before the cleaning fluid is added in the NBG. **Household Bleach** will remove any biological growth from the Lotus internal mechanism
3. **Introduce the cleaning solution.** Disconnect the gas tube at the upper side of the check valve as shown in the figure 15. Use the syringe and the CIP tube provided to inject the cleaning solution into the NBG.

Figure 15. CIP Tubing

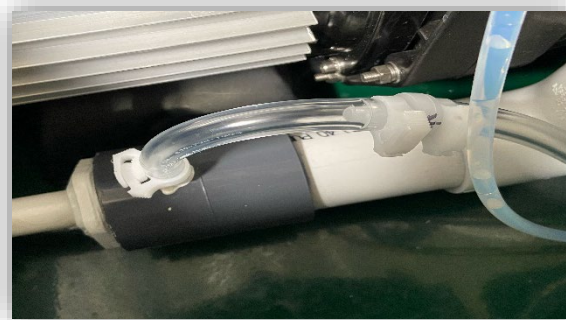

4. **Soak the cleaning solution.** Allow the cleaning solution to soak the NBG for a minimum of 10 minutes.
5. **Rinse the system.** Using cleaning water, thoroughly rinse out the system until all the cleaning solution is flushed out of the system and the water quality is satisfactory.
6. **Restart the system.** Reconnect all the tubes and pipes. Follow the startup process as described in the start-up section of this manual.

Operation Checklist

Model	Component	Instructions	
1	Power light	Check the light. Green: Running; Red: Powered but not running, No light: No power	
2	Gas Leakage	Use soapy water to check the gas leakage on the joints and fittings. Check for signs of cracking on the tubing	
3	Water Pressure	Check water pressure gauge (8-20 Psi). Compare value with the historical values on the checklist (included below)	
4	Gas Pressure	Check gas pressure gauge (8-24 Psi). Compare value with the historical values on the checklist (included below)	
5	Fan	Make sure fan is clean and running.	
6	Pump basket	Stop the unit. Close isolation valves, remove the pump lid. Inspect and clean the basket.	
7	Pump Visual inspection	Inspect the pump body. Look for signs of leakage, water, or heat marks on the junction box	
8	Rotameter	Check rotameter value and compare with previous readings.	
9	Air delivery check	Detach tube from the check valve on the gas delivery tube and confirm the gas flow.	
10	Visual inspection	Check gas tubing and look for spots with condensation, and heat marks. Detach tubes to drain water inside tubes.	
11	Power interruption test	Shut down the unit and power back on after 30 seconds. Monitor the unit until it goes back to normal operation	

Preventive Maintenance Checklist - Recommended Monthly

	Part Number	Description													
1	99V0-079	Solenoid valve													
2	45P0-001	Pump													
3	99J0-140	Gas Assembly													
4	99B0-036	Tubing													
5	45J0-003	Pressure Gauges													
6	NA	Gas Operating Pressure													
7	NA	Water Operating Pressure													

Troubleshooting Guide

Problem	Possible Cause	Corrective Action
Pump Will Not Prime	<ul style="list-style-type: none"> Air being drawn into pump suction. Gas valve open when pump not running. Air pocket in suction line. 	<ul style="list-style-type: none"> Check suction piping and valves on suction line. Secure lid on pump strainer basket and be sure lid gasket is in place. Check water level to make sure suction port. Check Pump strainer is full of water. Be sure valve on suction line is working and open
Pump Motor Not Running	<ul style="list-style-type: none"> Motor thermal protector tripped. Open circuit breaker or blown fuse. Defective pump. 	<ul style="list-style-type: none"> Check thermal protector. Check circuit breaker. If all above are in good condition, the pump is defective and should be replaced.
Reduced Capacity	<ul style="list-style-type: none"> Air pockets or leaks in suction line. 	<ul style="list-style-type: none"> Check suction piping and fully open any valve on suction and discharge lines
Insufficient Dissolved Oxygen Saturation	<ul style="list-style-type: none"> Vacuum leaks in suction line. Leaks in Oxygen tubing. Gas flow too low. 	<ul style="list-style-type: none"> Check air connections for leaks with soapy water. Increase gas flow. Increase system run time.
Pump Flow Too Low	<ul style="list-style-type: none"> Voltage too low. NPSH too high – excessive suction lift or losses. Pump back pressure too high. 	<ul style="list-style-type: none"> Ensure shortest possible distance to outlet. Check suction lift and loss. Maximum suction lift is 6' (2 meters). Check discharge pipe, maximum length 20 feet.
Pump Back Pressure Too High	<ul style="list-style-type: none"> Discharge piping obstructed. Discharge height too high. 	<ul style="list-style-type: none"> Check discharge nozzle and piping. Ensure discharge head is 10 feet or less
Low Gas Pressure on System Gauge	<ul style="list-style-type: none"> Feed gas pressure too low. 	<ul style="list-style-type: none"> Check for leaks in tubing with soapy water test.
Gas Flow Meter Not indicating flow	<ul style="list-style-type: none"> Moisture in the Rotameter. Compressed gas not getting to flow meter 	<ul style="list-style-type: none"> Clean and dry Rotameter. Check for leaks in tubing/connections
Large Bubbles	<ul style="list-style-type: none"> Gas flow too high. 	<ul style="list-style-type: none"> Reduce gas flow by rotating control knob on regulator
Insufficient Gas Transfer	<ul style="list-style-type: none"> Feed gas pressure too low. Delta gas pressure out of range. Internal system fouling. 	<ul style="list-style-type: none"> Increase feed gas pressure at the gas regulator. Clean Rotameter, gas lines, and fittings. Follow “clean-in-place” procedures for internal cleaning.
Excessive Noise and Vibration	<ul style="list-style-type: none"> Pump is not fully primed. NPSH too high Suction plugged, or valve closed. 	<ul style="list-style-type: none"> Completely flood intake piping to prime fully. Open discharge valve or reduce restrictions.

Limited Warranty

Limited Warranty

Moleaer warrants that the Goods will be free from defects in material and workmanship for a period of twelve (12) months from the date of first purchase (provided, however, that if Buyer is not able to provide proof of the date of purchase, the warranty period will run for eighteen (18) months from the date of manufacture) (the "Warranty Period"). Moleaer shall in no event be liable for defects or damage attributable to modifications performed or repair work done other than by Moleaer personnel or to abuse, accident, negligence, catastrophe, force majeure event, shipment, improper use including but not limited to circumstances where pumps and / or compressors included in the Goods are not operated in accordance with the original pump or compressor manufacturer's specifications, maintenance, storage or application or any other external cause. EXCEPT FOR ANY WRITTEN PERFORMANCE WARRANTY THAT MOLEAER HAS EXPRESSLY INCORPORATED IN THIS CONTRACT, THE GOODS ARE PROVIDED BY MOLEAER "AS IS" AND WITH ALL FAULTS, AND MOLEAER SPECIFICALLY DISCLAIMS ALL OTHER WARRANTIES OF ANY KIND, WHETHER EXPRESS, IMPLIED, STATUTORY OR OTHERWISE, INCLUDING WITHOUT LIMITATION, ANY WARRANTIES OF MERCHANTABILITY, TITLE, FITNESS FOR A PARTICULAR PURPOSE AND NON-INFRINGEMENT, TO THE MAXIMUM EXTENT PERMITTED BY APPLICABLE LAW. ANY IMPLIED WARRANTY THAT CANNOT BE DISCLAIMED BY LAW IS LIMITED TO THE DURATION OF THE WARRANTY PERIOD. MOLEAER DOES NOT WARRANT THAT THE GOODS WILL MEET BUYER'S REQUIREMENTS OR ACHIEVE ANY SPECIFIC RESULTS. WITHOUT LIMITING THE GENERALITY OF THE FOREGOING, BUYER ACKNOWLEDGES AND AGREES THAT BUYER IS SOLELY RESPONSIBLE FOR USE OF THE GOODS COMPLIANCE WITH APPLICABLE LAWS, RULES AND REGULATIONS.

Claims; Exclusive Remedy

Any warranty claim must be made to Moleaer in writing within ten days of discovery of the alleged defect. After obtaining prior written authorization from Moleaer, Buyer shall return all allegedly defective Goods, freight pre-paid, for examination by Moleaer. If Moleaer finds that the Goods are defective and covered by the warranty, Moleaer's sole obligation shall be, at Moleaer's option, to repair or replace the Goods, or to refund the purchase price therefor, and to reimburse Buyer's reasonable shipping costs. Buyer shall be responsible for all charges for handling of returned items not found defective. The remedy set forth in this Paragraph is Buyer's sole and exclusive remedy for any breach of warranty or claim related to the Goods other than pursuant to any written performance warranty that Moleaer has expressly incorporated in this Contract.

PLEASE CONTACT MOLEAER AT 4245583567 IF YOU HAVE ANY QUESTIONS, OR TO ASSIST WITH ANY TROUBLESHOOTING AND FIELD INSTALLATION QUESTIONS.

MOLEAER[®]
ADVANCING NANOBUBBLE TECHNOLOGY

20800 BELSHAW AVENUE
CARSON, CA 90746 USA
+1-424-558-3567
info@moleaer.com
www.moleaer.com
Revision 07052022