

## Drum Fan Owner's Manual

**Model:**

**FD-630D**

(115V 60HZ)

Read and save these instructions before use



**Intertek**

[www.xpower.com](http://www.xpower.com) | 1-(855)-855-8868 | [info@xpower.com](mailto:info@xpower.com)

Index: NA-1-A39  
Edition: 1.0.Alpha

# Safety Instructions

## **⚠ WARNING - READ AND SAVE THIS INSTRUCTIONS BEFORE USING THIS PRODUCT.**

The user of electrical products may create hazards that include, but are not limited to injury, fire, electrical shock. Failure to follow these instructions may damage and/or impair its operation and void the warranty.

- Before operating, remove all packaging material and check for any damage that may have occurred during shipping or any missing items.
- Check household power supply to ensure it matches the appliance's specification.
- **DO NOT** operate any fan with a damaged cord or plug. Discard fan or return it to an authorized service facility for examination and/or repair.
- Use only on GFCI protected receptacles. Please contact a qualified electrician for verification and / or installation of a GFCI receptacle if necessary.
- **DO NOT** run cord under carpeting. **DO NOT** cover cord with throw rugs, runners, or similar coverings. **DO NOT** route cord under furniture or appliances. Arrange cord away from traffic area and where it will not be tripped over.
- Suitable for use with solid state speed control.
- **DO NOT** touch this appliance or the plug with wet hands or while standing in water.
- **DO NOT** operate the appliance in any pooled water.
- **DO NOT** use the product in areas where gasoline, paint or other flammable goods and objects are used or stored.
- **DO NOT** insert or allow objects to enter any ventilation or exhaust opening as this may damage the appliance and void the warranty.
- **DO NOT** cover the air inlet or outlet on the appliance.
- **DO NOT** direct the air flow at human faces or bodies.
- **DO NOT** allow children to play around or with this appliance.
- **AUTOMATICALLY OPERATED DEVICE** – To reduce the risk of injury, disconnect from power supply before servicing.
- Remove the power cord from the electrical receptacle by grasping and pulling on the power cord plug-end only, **DO NOT** pull the cord directly.
- **DO NOT** attempt to repair or adjust any electrical or mechanical functions of this appliance, as this may cause danger and void the warranty.
- If the appliance is damaged or it malfunctions, **DO NOT** continue to use it. Unplug the product from the electrical outlet. Refer to troubleshooting guide or contact XPOWER.
- Store in a dry area, away from exposure to sunlight, extreme temperature and humidity, or other extreme environments, when not in use.
- An electronic instruction manual can be obtained through manufacture's website [www.xpower.com](http://www.xpower.com).



## Items Included

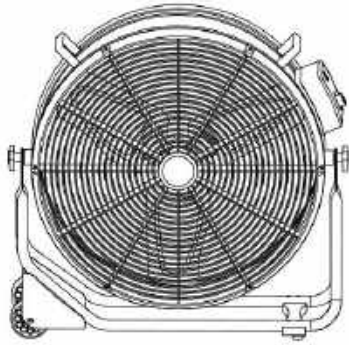

• Drum Fan x 1



• Owner's Manual x 1

## Parts Description

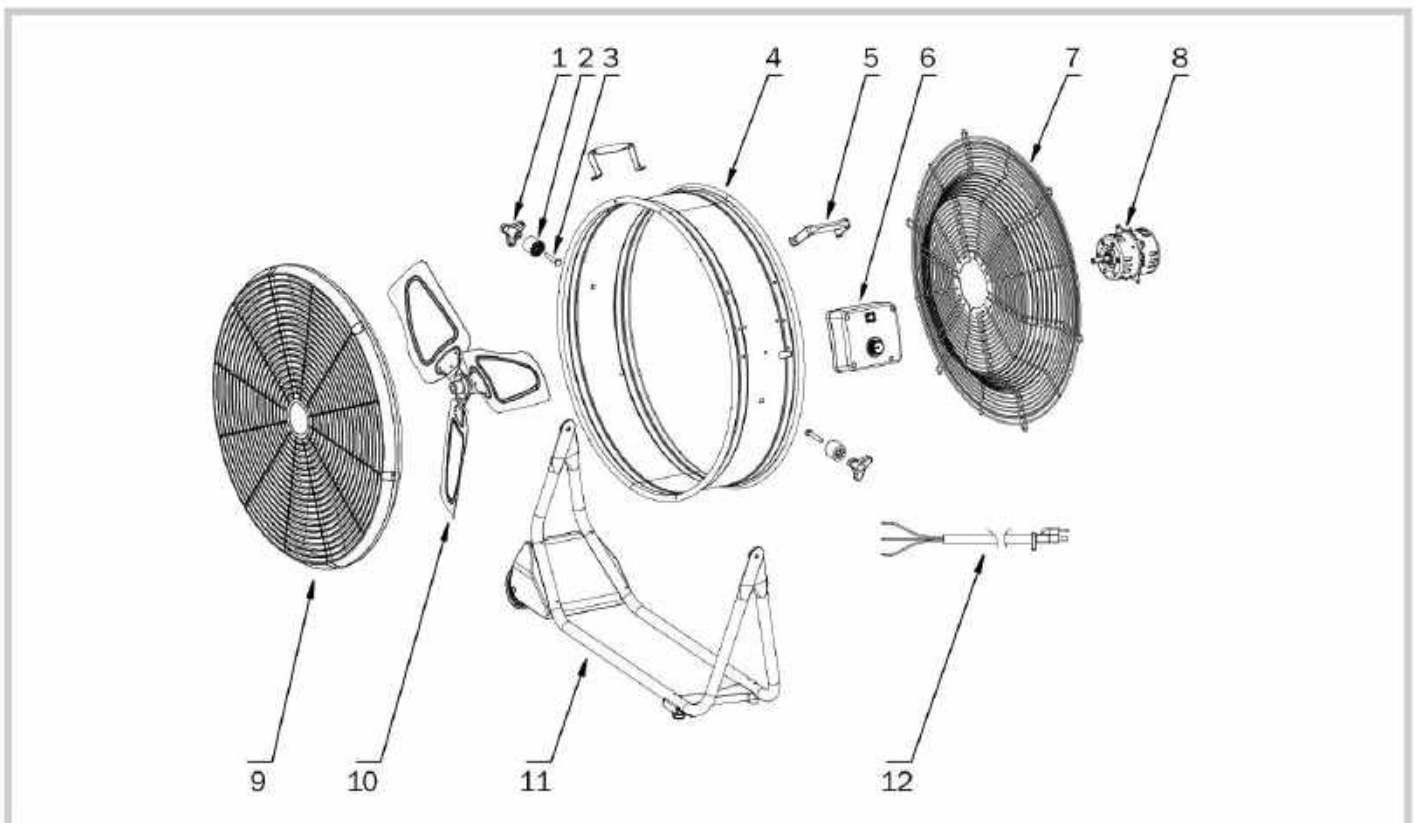

- |                  |                           |                        |
|------------------|---------------------------|------------------------|
| (1) Rack Handle  | (5) Housing Handle        | (9) Front Grille Cover |
| (2) Friction Pad | (6) Switch Plate          | (10) Fan               |
| (3) Screw M8X50  | (7) Rear Air Grille Cover | (11) Rack              |
| (4) Housing      | (8) Motor                 | (12) Power Cord        |

# Drum Fan Introduction

- XPOWER Drum Fans are designed to create a cool zone for both indoor and outdoor with its huge amount of “natural feeling” airflow and efficient powerful brushless DC motor.
- It's perfect for indoor and outdoor activities and events where efficient ventilation, cooling or even stage effects of wind are needed.
- The brushless DC motor technology allows efficient airflow output with less energy than conventional motors as well as a wide range airflow adjustment from 10 to 9500 CFM.

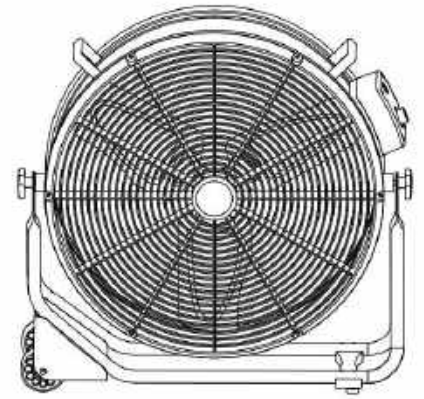

## Operation Guide

### SWITCH PLATE

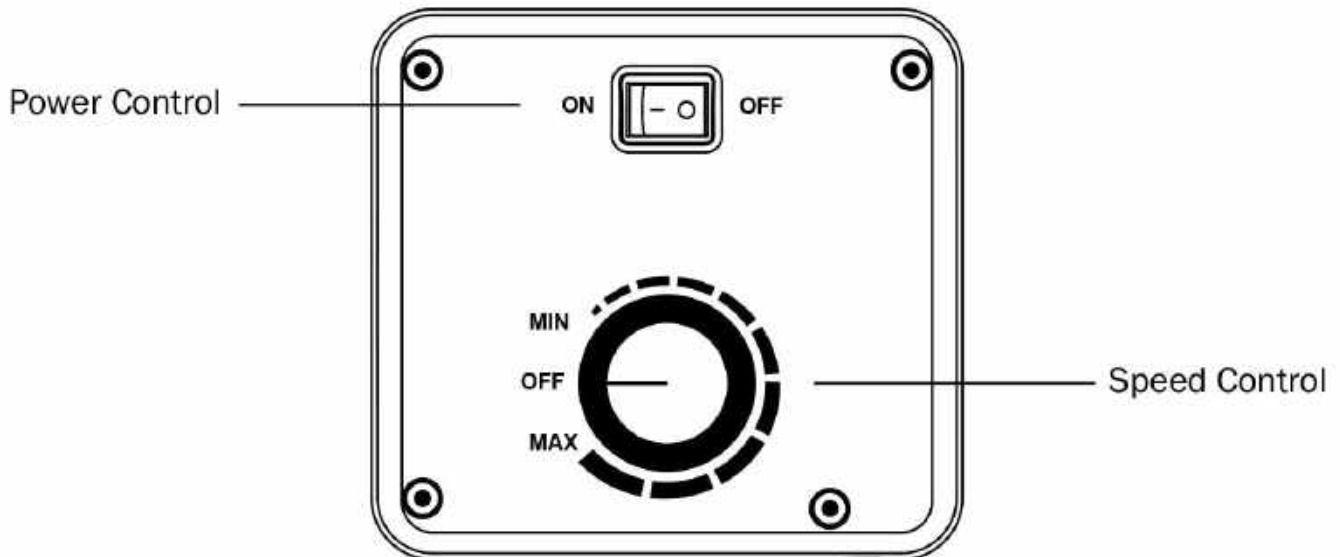

#### Power Control

- Switch to “**OFF**” position to disconnect the drum fan from the power. Switch to “**ON**” position to connect the drum fan from the power.

#### Speed Control

- Turn to “**OFF**” position to switch the drum fan OFF. Turn clock-wisely to any position between “**MIN**” and “**MAX**” to switch the drum fan ON.
- You can adjust to any desired speed variably.

#### IMPORTANT

- When finished, turn the speed control to “**OFF**” position to switch the drum fan OFF first, and then turn off the power control.

# Operation Guide (Continued)

## Adjust Operating Position

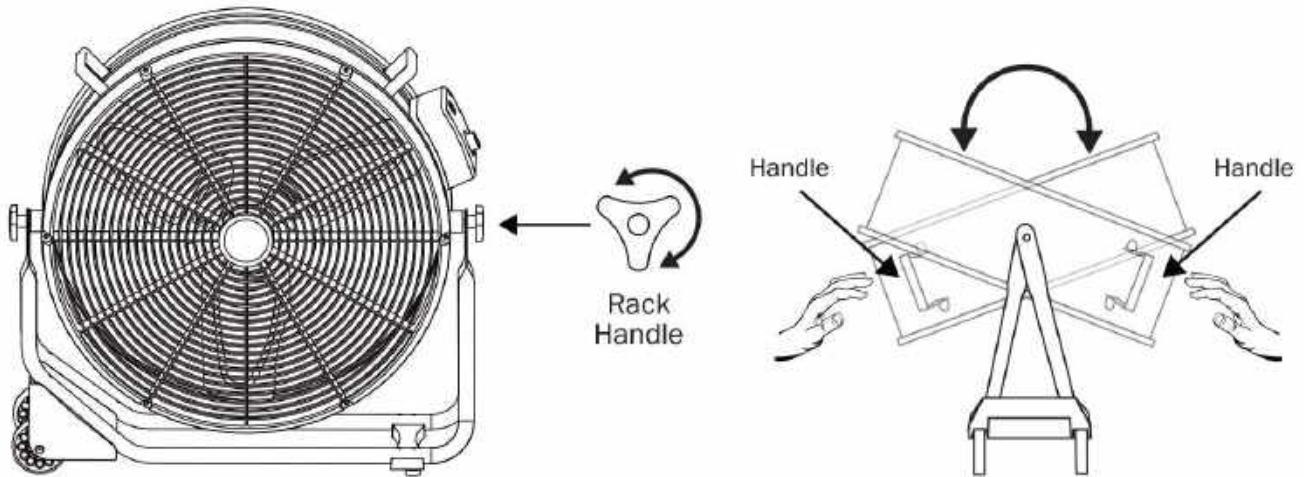

- The position of the drum fan is held by the rack handles on the rack.
- To adjust the operating position, turn anti-clock-wisely to loosen the rack handle and then use the handle to rotate the drum fan and adjust to desired position.
- Turn clock-wisely to fasten the rack handle and hold the position of the drum fan. Make sure it's tight enough when the fan is working.

## Transportation

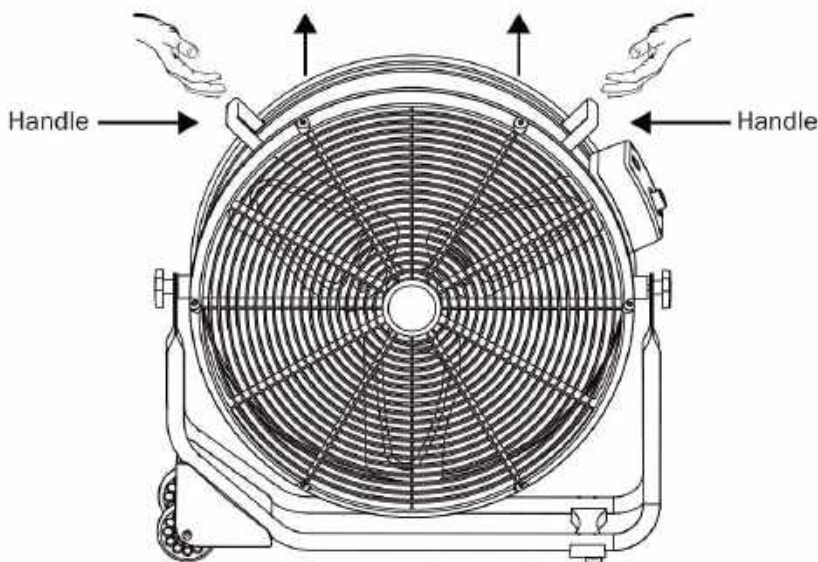

### Lift with Handles

- Lift the drum fan with the two handles on the top.
- Be aware of the weight of the machine.



## Operation Guide (Continued)

### Transportation (Continued)

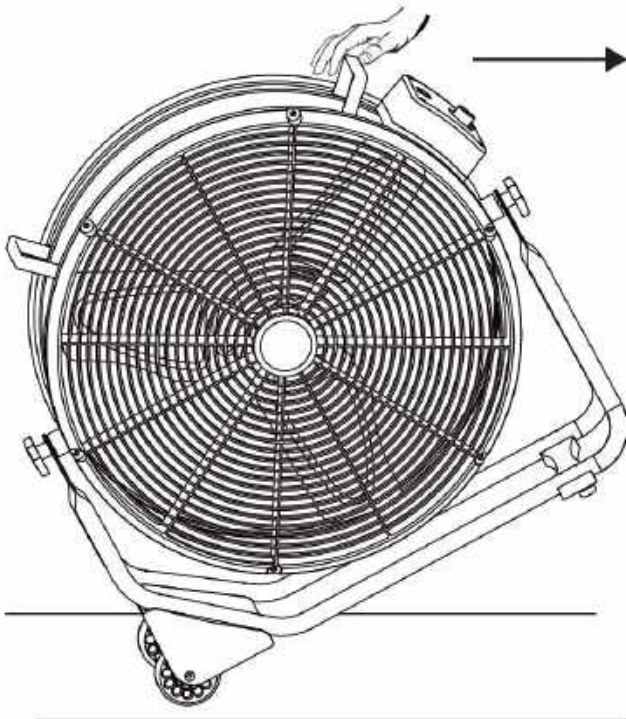

#### Transport on Wheels

- Lift the drum fan with the handle shown on the left.
- Pull with the handle and transport the drum fan.

## User Maintenance Instructions

Frequent maintenance is recommended on this appliance. Failure to follow the maintenance instructions may cause failure of the appliance and void the warranty.

- When not in use, unplug and store the appliance in a dry and cool indoor place. Make sure it's out of reach of children.
- Before performing any maintenance or cleaning, always disconnect the air mover from its power source.
- Use a damp cloth to wipe the surface of the housing. Do not clean the unit with water directly.
- Check if the grille covers are clean. Remove dirt or any other objects that could block the air inlet and air outlet.

## User Maintenance Instructions (Continued)

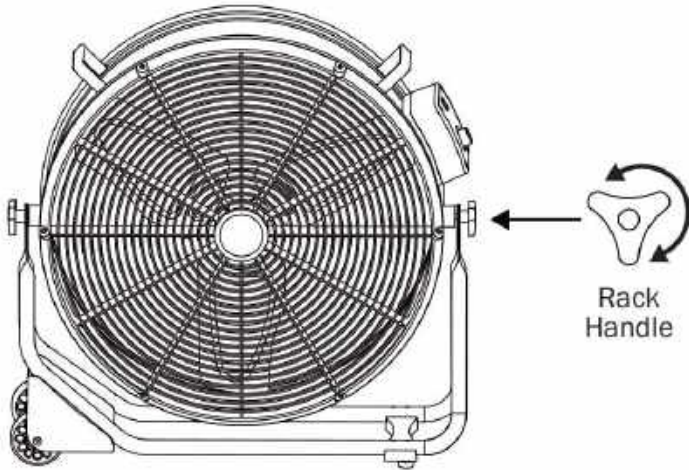

### Fasten the Rack Handles

- To prevent possible injury, when you finish using this appliance, please position the drum fan **UPRIGHT**.
- Fasten the rack handle to lock the position of the drum fan.

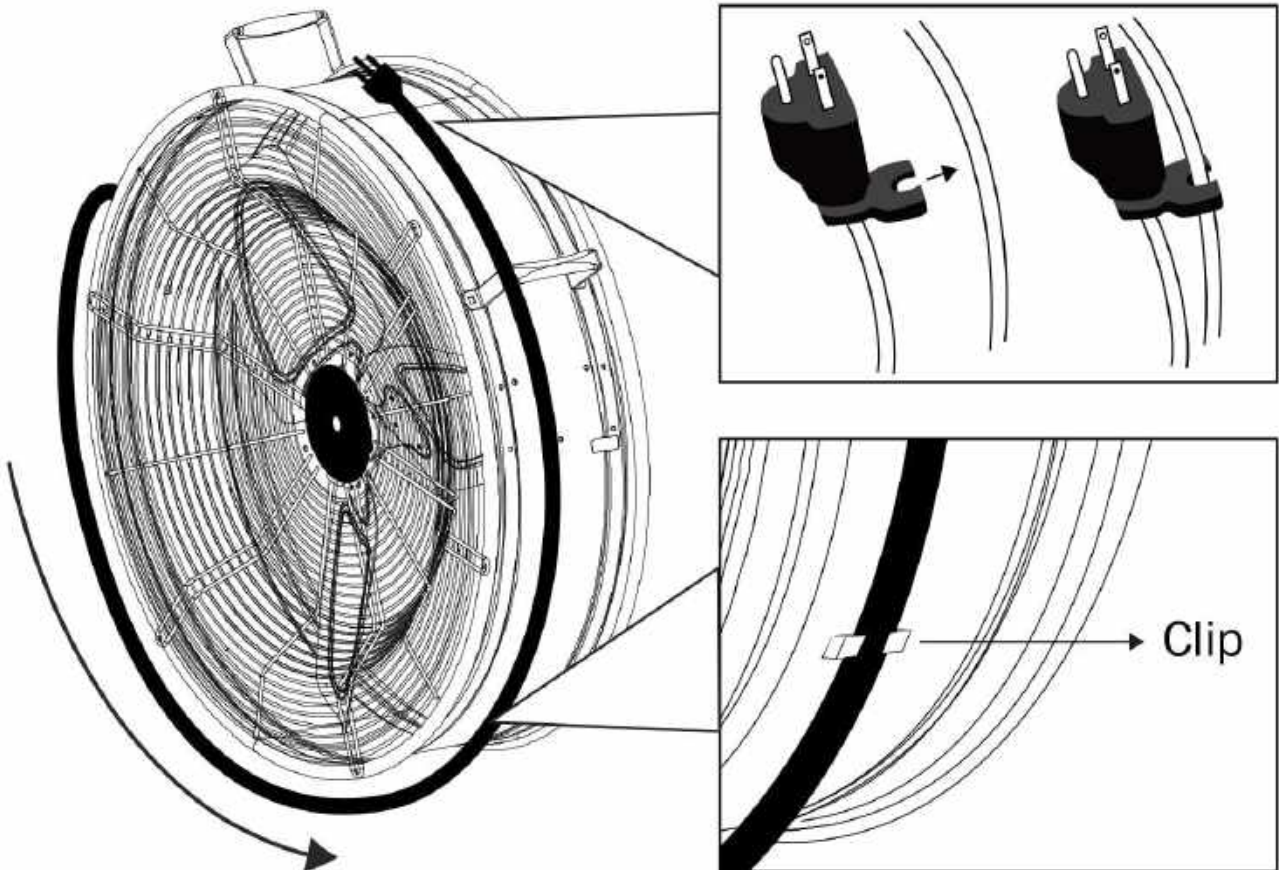

### Organize the Power Cord

- Wrap the power cord around the housing, close to rear of the drum fan.
- Clip the cord to the cord clip on the plug and the drum fan shown above.

# Troubleshooting Guide

PROBLEM	POSSIBLE CAUSE	SOLUTION
Drum fan does not start	No electricity.	Check for power supply.
	The power cord is not properly plugged in.	Remove and reconnect the power cord.
Unit runs but the speed is abnormal	Air inlet or air outlet is blocked.	Remove blockage.

If troubleshooting does not resolve your problem, please contact XPOWER or other parties authorized by XPOWER for further instructions.



# Technical Specification

MODEL NUMBER	FD-630D
Voltage/ Frequency	115 V~60 Hz
Amperage	1.8 A
Motor Power	1/2 HP
Rated Airflow	10 CFM - 5800 CFM
Speed Control	Variable Speeds
Cord Length	10 ft. / 3 m
Unit Dimension (L) x (W) x (H)	30.1 x 9.3 x 29.0 in. / 76.5 x 23.5 x 73.5 cm
Unit Weight	29.3 lbs. / 13.3 kg
Safety Certification	ETL/C-ETL

If your product(s) is not listed above, please visit [www.xpower.com](http://www.xpower.com) for more information.

# XPOWER Limited Warranty (USA)

## 1 YEAR LIMITED WARRANTY

XPOWER-branded products purchased in the U.S. from authorized distributors include a 1-year limited warranty. Contact XPOWER to confirm warranty information about your product(s).

This limited warranty covers defects in materials and workmanship in your XPOWER-branded products, purchased in the **U.S. ONLY**. Local warranty policy (if any) in your country will cover products purchased outside the U.S.

### **IMPORTANT:**

- (1) Please finish the online warranty registration before usage. Visit [www.xpower.com/service-support/warranty-registration](http://www.xpower.com/service-support/warranty-registration).
- (2) This Limited Warranty applies with its own timeliness. Contact XPOWER or visit [www.xpower.com](http://www.xpower.com) for more information.

### **Items mentioned but not limited to below are not covered by warranty:**

- (1) Power cord, filters or any other components considered as a “consumable parts” by XPOWER.
- (2) Normal wear and tear.
- (3) Problems that result, directly or indirectly, at XPOWER’s sole discretion, from:
  - (3.1) External causes such as accident, abuse, misuse or problems with electrical power supply.
  - (3.2) Disassembling, servicing or modification not authorized by XPOWER.
  - (3.3) Usage that is not accordance with product instructions stated in Owner’s Manual.
  - (3.4) Failure to follow the product instructions or lack of necessary maintenance stated in Owner’s Manual.

### **Before contacting XPOWER, please try one or more of the following:**

- (1) Consult this Owner’s Manual and follow the instructions of troubleshooting guide.
- (2) Access [www.xpower.com](http://www.xpower.com) for more advice and information that could be helpful to address your problems.

### **If you need additional assistance from XPOWER, please:**

- (1) Email [info@xpower.com](mailto:info@xpower.com).
- (2) Call XPOWER U.S. Customer Service Department at **855-855-8868** or other numbers provided on [www.xpower.com](http://www.xpower.com).
- (3) Visit XPOWER U.S. Head Office at [240 Clary Ave., San Gabriel, CA 91776](http://www.xpower.com) or the most current address provided on [www.xpower.com](http://www.xpower.com).

Please also have your original proof of purchase and the serial number(s) of your product(s) ready when you contact XPOWER.

## XPOWER Limited Warranty (USA) (Continued)

**If you are instructed to return the unit for service or replacement, please:**

- (1) Request a RMA (Return-Merchandise-Authorization) number.
- (2) Use the original or an equivalent packaging, prepay shipping charges at your own expense to the address provided by XPOWER, with the RMA number on the shipping label or the packaging.
- (3) Include all the original parts and components.

XPOWER will inspect, assess and advise the repairs needed and applicable cost, if any. For products under warranty, we will pay to ship the repaired or replaced product(s) to you if you use an address within the Contiguous United States. Otherwise, we will ship the product(s) to you at your own expense.





**XPOWER Manufacture, INC.**

668 S. 6Th Street

City of Industry, CA 91746

[www.xpower.com](http://www.xpower.com) | 1-(855)-855-8868 | [info@xpower.com](mailto:info@xpower.com)

Read and save these instructions before use

---

Index: NA-1-A39

Edition: 1.0. Alpha