

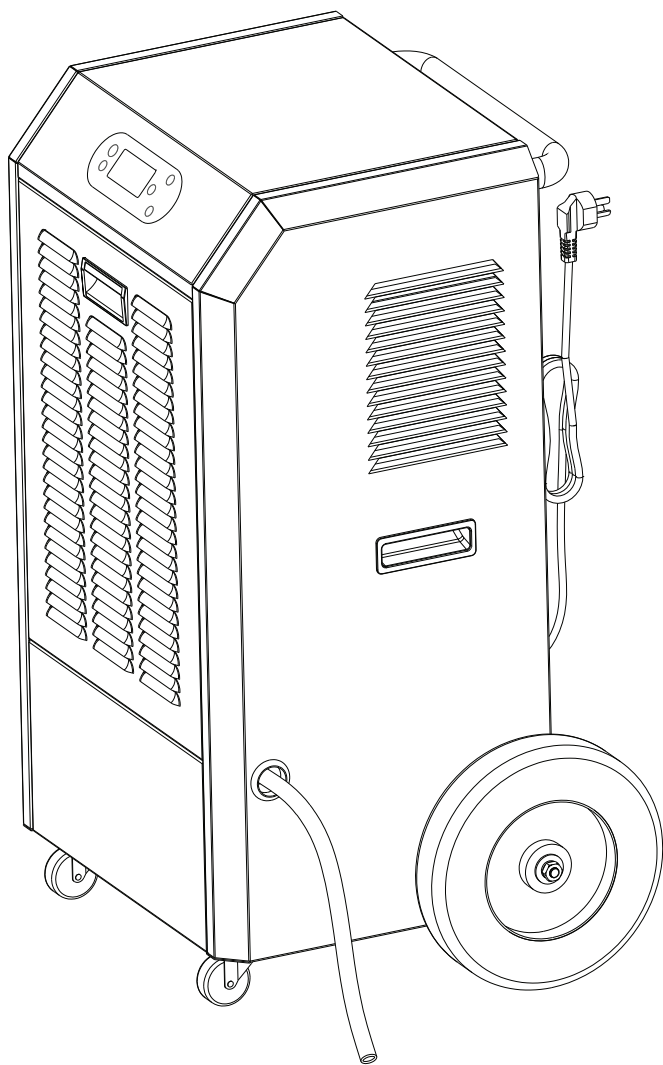

INSTRUCTION MANUAL

DEHUMIDIFIER AADHC180P



PLEASE KEEP THIS MANUAL FOR FUTURE REFERENCE!

Thank you for selecting Active Air dehumidifiers. This manual details the proper use and maintenance of these dehumidifiers. Please take a few minutes to read this manual, and please keep it for further reference.

FEATURES

- Large capacity
- Moveable and easy to store
- Built-in auto defrost system to protect key working components
- Adjustable humidity
- Timed operation
- Quiet running
- Energy-saving design

SPECIFICATIONS

Model#	AADHC180P
Rated capacity	180Pints/ Day
Power supply	120V / 60Hz
Rated input current	11.3A
Rated input power	1350W
Max condenser pressure	3.6MPa
Max evaporator pressure	1.2MPa
Freon type & capacity	R410a / 750g
Grade of waterproof	IP-X1
Weight	116 lbs
Operating ambient temperature	41° F – 95° F
Test conditions	86° F, RH80%

WARNINGS

Please follow the below safety guidelines when using the dehumidifier:

- Unplug the power supply when cleaning or storing the unit.
- Do not put into water or operate near a water source.
- Do not place the unit near the heat equipment or Inflammable dangerous goods
- Keep fingers and other objects away from air inlets and outlets.
- Do not stand on the unit.
- Do not cover the louvered panes on the machine or it will overheat.
- Install the drainpipe facing downward so condensation will flow out of the pipe.
- If the power cable is damaged, please contact a licensed electrician for replacement or repair.

INSTRUCTION MANUAL

PRODUCT DRAWINGS

FRONT

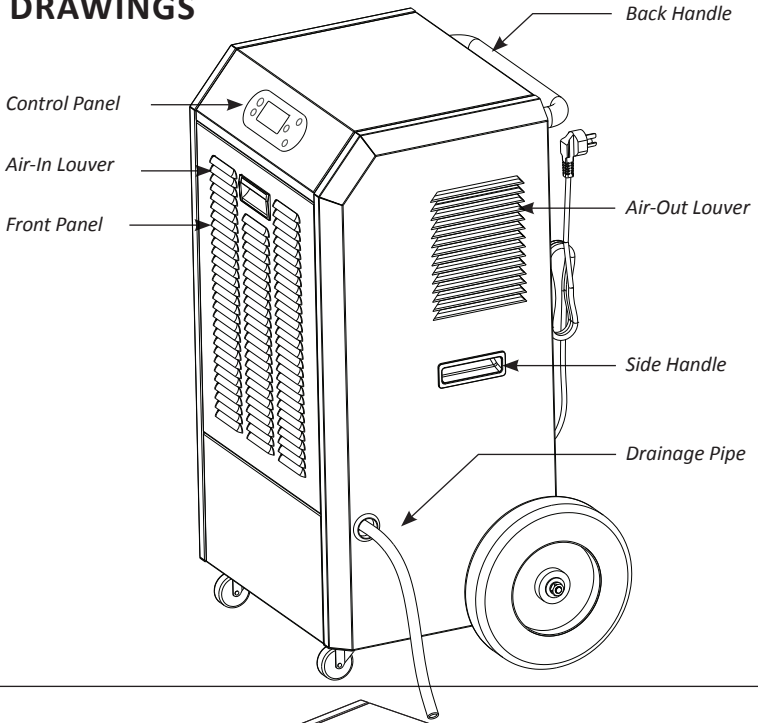

BACK

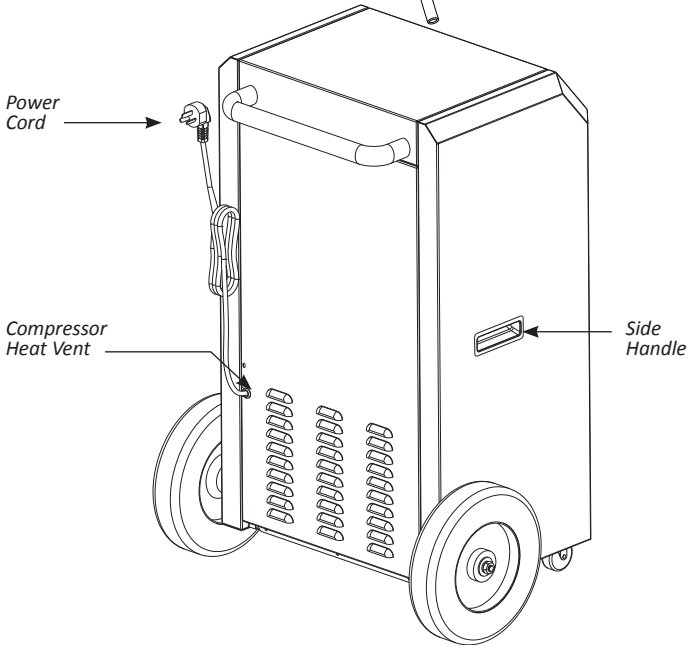

DRAINAGE INSTALLATION

Install the included drain pipe to the draining nozzle on the machine and direct the pipe to the desired area before operate the machine.

If in need to replace or extend the drainage pipe, use ID Ø16mm, or 5/8in, piping.

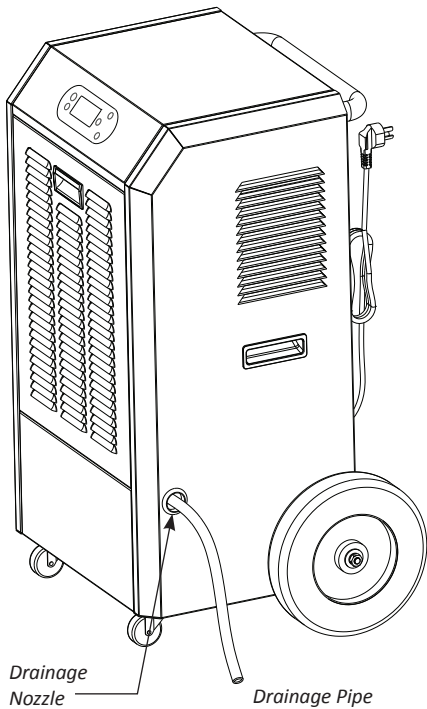

WARNING: Do not block the drainage hose. The end of the drainage pipe should not be higher than the outlet hole. If the drainage pipe end is higher than the outlet hole, water will not drain properly and could damage components of the unit.

MACHINE SETUP AND OPERATION



KEY FUNCTIONS

POWER – Turns the unit on and off.

CONTINUOUS OPERATION – When pressed, the unit will operate continuously.

TIMER/MODE – The unit has 5 modes: Humidity, Current Time, Timed Operation On, Timed Operation Off, and Exit. Every time you press the Timer/Mode key it cycles to the next mode.

“+” KEY – When in the **“SET”** mode, every time you press the **“+”** key, it will raise the humidity by 1%. If you hold the key down, it will add humidity more quickly. When in any of the time modes, the **“+”** key adds hours. These keys are used to set **“CURRENT”** time, **“TIMING ON”**, and **“TIMING OFF”**.

“-” KEY – When in the **“SET”** mode, every time you press the **“-”** key, it will lower the humidity by 1%. If you hold the key down, it will lower humidity more quickly. When in any of the time modes, the **“-”** key adds minutes. These keys are used to set **“CURRENT”** time, **“TIMING ON”**, and **“TIMING OFF”**.

HUMIDITY AND TIMER SETUP

When the machine is powered on for the first time there will be an audible buzz sound. Please note that the machine has a default setting for humidity.

1. Press the **POWER** button to start the machine. The screen will display **“Run”** and **“Current,”** the present humidity.

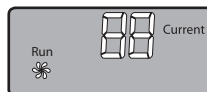

INSTRUCTION MANUAL

- To set the desired humidity, press the **TIMER/MODE** button. The screen shows “Set” and the machine enters into the set mode. When in the set mode, you can increase or decrease the humidity from the default setting to your desired level by using the “+” or “-” buttons.

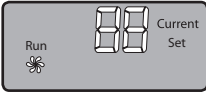

ATTENTION: The machine default humidity setting may be lower or higher than the current ambient humidity when the machine is powered on for the first time. If the default humidity is higher than the current humidity, after the machine is powered on, although the fan will operate, the dehumidify function will not operate. You are required to reset the humidity to your desired level in order to ensure the machine will operate properly.

- To set the current time, press **TIMER/MODE** again to see the present time. You can change the time by using the “+” button to change hours and “-” button to change minutes.

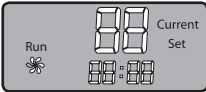

ATTENTION: The time format is in 24 hours and the default time is set at 12:00. You can choose to skip the current time setting by pressing the **TIMER/MODE** button to cycle to exit. However, if the machine operates by the default current time, the Timing On and Timing Off function, if set, will operate according to the default current time, but not the real current time. You are highly recommended to set the current time.

- To set for timed operation, press **TIMER/MODE** a third time and “Timing on” will display. Use the “+” button to change hour and the “-” button to change minutes. The timer is in 24-hour format.

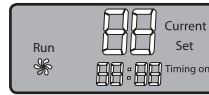

- After you press **TIMER/MODE** a fourth time, “Timing off” will display. Use the “+” button to change hour and the “-” button to change minutes.

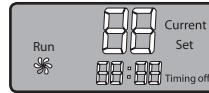

TIP: You can choose to skip the Timing on and Timing off setting by pressing the **TIMER/MODE** button to exit. If so, you must manually power the machine on or off each time by pressing the **POWER** button.

- Press **TIMER/MODE** a fifth time to exit the setting mode.



OPERATIONS

Non-timed dehumidifying operation to the desired humidity level

When the timer is not set, the unit dehumidifies toward the humidity set point and automatically goes to the standby mode when the set point is achieved. After the ambient humidity increases more than 3%, the dehumidifying function operates again. The machine will continue working in this pattern until it is manually powered off.

Due to the 3-minute on/off delay design to protect the working components (see *On/Off Delay*, page 6), the humidity reading may go up more than 3% while the machine remains in the standby mode since it is within the 3-minute delay protection period. This usually happens in the condition that the ambient humidity is high. It is not a machine malfunction.

Timed dehumidifying operation to the desired humidity level

When the timer is set, the machine will operate according to the humidity set point (see page 5, step 2), only after the Timing On time and before the Timing Off time. Before the Timing On time and after the Timing Off time, the machine is in standby mode. Unless the power supply cord is unplugged, the machine remembers all set points in the standby mode and will automatically operate according to the timer setup every day.

You can manually override the timer function to start or stop the dehumidifying function by pressing the **POWER** button. The machine resumes to the timer mode in the next 24-hour cycle.

Automatic Defrost

The unit will automatically go into defrost mode when frost forms on the evaporator coil. The screen shows "**Defrost.**" After 15 minutes of defrost time the unit will resume operation. When in the defrost mode, the unit does not dehumidify.

Continuously dehumidify operation

When the machine is in continuous operation, the desired humidity set point is still remembered but is deactivated. The machine will continuously dehumidify, no matter what the humidity set point is, until it is manually powered off or timed off.

1. Press the **CONTINUOUS OPERATION** button to enter the continuous operation mode. The screen will show "**Continuous.**"

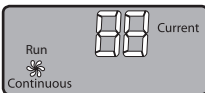

2. Press the **CONTINUOUS OPERATION** button again to deactivate continuous operation. The machine goes back to the mode of operating according to the humidity set point.

When there is a frost buildup, the machine will be forced to stop dehumidifying and start defrosting automatically. The screen shows the machine in "**Defrost**" process under "**Continuous**" mode. After the defrost function ends, "**Defrost**" disappears from the screen while "**Continuous**" still shows.

Automatic Restart

In the event of a power failure, the machine will remember what the humidity set point was and whether the unit was in operating mode before the power failure.

When power is restored, if the unit was operating before the power failure, it automatically restarts to operate according to the humidity set point in the non-timed mode.

If the unit was not operating before the power failure, the unit remains in non-working condition.

Current Time, Timing On, Timing Off and Continuous Operation set points will not be remembered when power failure occurs. They must be reset when the power is restored.

The Automatic Restart feature allows the unit to be used with controllers and timers.

On/Off Delay

If the system is turned off after running and you wish to turn it on again, there is a 3-minute delay before restart as protection to the working components of the unit.

MAINTENANCE

1. Clean the machine with a soft wet cloth.
2. Pull out the louver on the front panel to gain access to the filter.

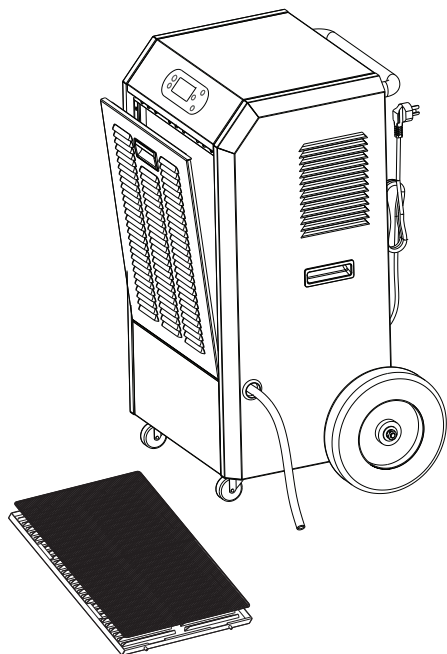

3. Remove the filter mesh out of the unit.
4. Use a clean rag to absorb the surface dust on the filter mesh. If the filter is extremely dirty, use tap water to flush the filter. Fully dry the filter before putting it back into the air inlet fence. A clean filter will increase the machine's capacity.

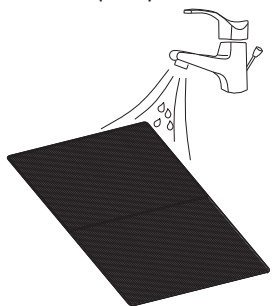

MACHINE STORAGE

If you don't use the unit for an extended period of time, please store it per the following steps.

1. Clean the filter mesh.

ATTENTION: The evaporator inside the machine has to be dried out before the unit is packed to avoid component damage and molds. Unplug the unit and place it in a dry open area for a few days to dry it out.

TIP: Another way to dry the unit is to set the humidity point higher than the ambient humidity to force the fan to dry the evaporator for 30 minutes. The dehumidifying function will not work and the fan can accelerate the drying process.

2. Collect the power cord, bunch it, and hang it in the power cord pocket at the back of unit.
3. Store the unit in a clean, dry environment.

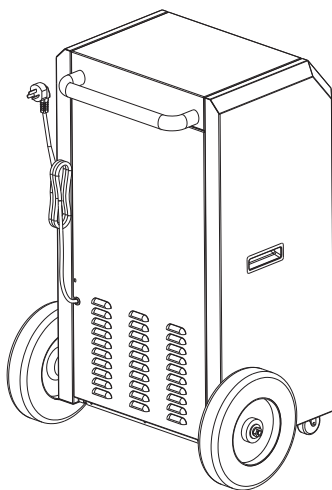

INSTRUCTION MANUAL

TROUBLE SHOOTING

Please try the following solutions before requesting after-sale service.

TROUBLE	CAUSE	SOLUTION
Machine does not run	Unit is not plugged in.	Plug in the unit.
	Ambient temperature is under 5 degrees or above 35 degrees.	To protect the machine, use it only when ambient temperature is between 5 and 35 degrees.
	The humidity sensor is loose, wet or defective; the screen will show "E5".	Check the sensor connection. Use a blower to dry the humidity sensor behind the front cover. If the machine still does not run, contact your retailer to replace the sensor.
	The temperature sensor is loose or defective; the screen will show "E6".	Check the sensor connection. Contact your retailer to replace the sensor.
Machine runs but does not dehumidify	The humidity set point is higher than the ambient humidity.	Reset the humidity to a lower set point, or power off the machine if the desired humidity level has been reached.
Reduced dehumidifier capacity	Filter mesh is jammed.	Clean the filter mesh according to manual.
	Air-in and/or Air-out louvers are jammed.	Clear the blockage from Air-in and/or Air-out louvers.
No air inlet	Filter mesh or Air-in louver is jammed.	Clean filter according to instructions or clean the louver blockage.
Loud Operation	Machine is situated on an incline or decline slope.	Move to a level location.
	Filter mesh is jammed.	Clean filter mesh according to instructions.

WARRANTY

Hydrofarm warrants the dehumidifier to be free from defects in materials and workmanship. The warranty term is one year beginning on the date of purchase. Misuse, abuse, or failure to follow instructions is not covered under this warranty. Hydrofarm will, at our discretion, repair or replace the unit covered under this warranty if it is returned to the original place of purchase. To request warranty service, please return the dehumidifier, with original sales receipt and packaging, to your place of purchase. The purchase date is based on your original sales receipt.



AADHC180P_instrux_12.2014